

Quick-TECH

Quick-TECH Machinery Co., Ltd.

the Art of turning machine



quicktech

Quick-TECH Machinery Co., Ltd.

709 No.35 Keji 1st Road Tainan City, Taiwan, R.O.C
Tel-No : +886-6-3841166 Fax-No : +886-6-3841177
http://www.quicktech.com.tw e-mail : inquiry@quicktech.com.tw



quicktech   
ENGINEERING AUS DEUTSCHLAND

**CNC MACHINE
TOOLS
MANUFACTURING**



www.quicktech.com.tw

Intention to make Engineering Technology

T8 Hybrid-Y Hybrid

Feature :

- Power turret and flexible gantry type tooling system
- Synchronous spindles
- Up to 24 live tools with powerful motor
- Double programs for cycle time saving
- 25 bar coolant pressure
- Free angle B axis 360° for all the angular tapping and drilling
- Yaxis is offered alternatively

Cycle time can be saved up to **45%**

Flexible **duo** system simultaneous

The system allows running **2** programs simultaneously

Mitsubishi AC Servo 11 kw
A2-6 main spindle with **66 mm** bore

With available heavy duty power turret, flexible gantry tools for sub spindle and C-axis capabilities, milling and turning applications is completed in one single machine.

They are ideal for producing complicated and single parts in high production demand.

BMT-55 Power Turret

Turret with 12 stations can be additionally equipped with driven tools on six stations. In connection with the driven tools, the main spindle is C-axis and Yaxis functional for accurate positioning.

Gantry Tooling

more flexible more functions

The unique gantry tooling system is extremely flexible. The standard tooling system allows for 5 external tools, 9 internal tools and 12 live tools.

The ER20 spindles are gear driven, with rigid tapping as standard. Up to 26 tools load for machining

Mitsubishi AC Servo 5.5 kw

A2-5 sub spindle with **32 mm** bore

The cartridge type spindle runs on P4 high precision bearings giving high radial and axial stability, allowing for heavy duty cutting. The spindle is assembled and tested in a temperature controlled clean room, sealed, and requires no maintenance.

The spindle housing is large, and symmetrically ribbed to allow heat dissipation and thermal stability.

Intention to make Engineering Technology

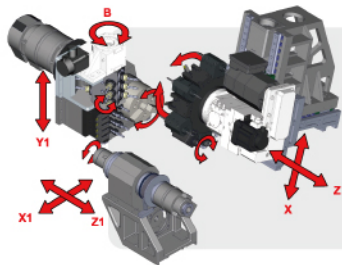

T8 Hybrid

The T8 series will help you be more competitive by achieving faster cycle times with heavier cuts, faster machine movements, and allow cutting tough material efficiently in a limited space.

Y-axis

The turret is mounted on a secondary 75 degrees wedge saddle on top of the X-axis slide from one - piece casting. Both X and Y axes have extra wide hardened and linear ways to assure the rigidity and accuracy.

Y-axis control further enhances multi-tasking live tooling capabilities and improves various machining precision.

With Y-axis travel 80 mm(=±40mm) , a wide variety of parts can be efficiently machined.

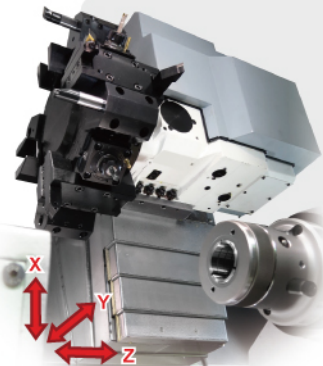
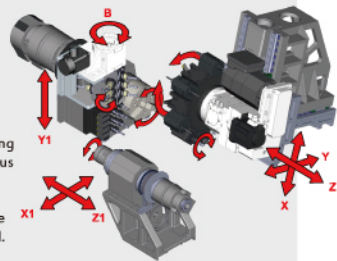

Machining applications

- 1/ Twin Spindle superimposed machining
- 2/ Simultaneously Double Process Running
- 3/ Long work-piece machining
- 4/ Live tool milling on main spindle
- 5/ Y axis milling on main spindle
- 6/ Off-center milling function
- 7/ Tapping or drilling by free Angle B axis on sub spindle

Gantry Tooling interference

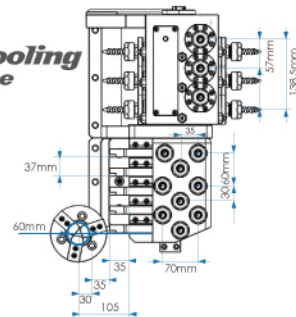

Turret interference

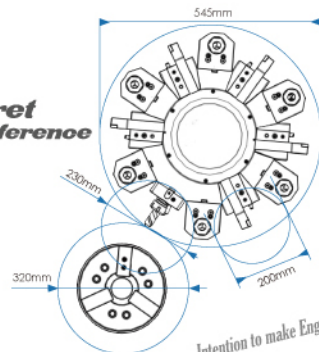

Intention to make Engineering Technology

T8

Twin-Y
Twin
Classical

Feature :

- Power turret for rigid heavy cutting
- 11KW spindle power
- Synchronous Spindles
- 25 bar coolant pressure
- Y axis is offered alternatively
- Programming tail stock is also available for the long work piece



The T8 series offers different combinations for varieties of mass production given better access to the turret and 8" or 10" chuck and also efficient chip removal.

T8 Twin

This series packed with sub spindle and BMT turret with 12 stations which can be additionally equipped with driven tools on six stations. In connection with the driven tools, the main spindle is C-axis functional for accurate positioning.

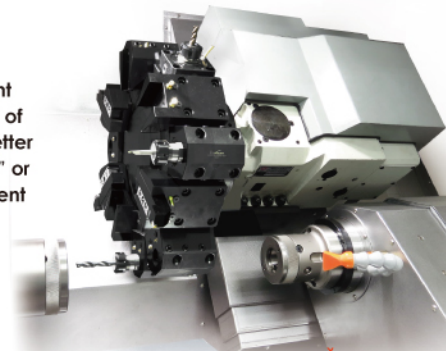
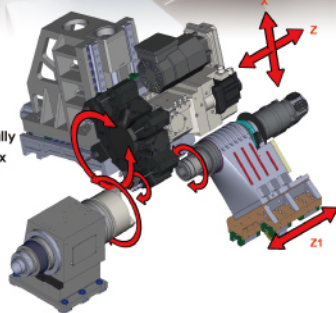

Classical

The standard slant-bed machine packed with servo turret with 12 stations and programming tailstock.

It offers the great cost-performance for efficient turning operations for chuck parts.

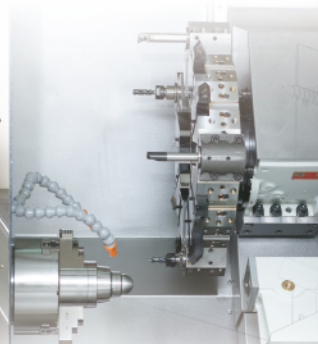

Y-axis

The turret is mounted on a secondary 75 degrees wedge saddle on top of the X-axis slide from one - piece casting. Both X & Y axes have extra wide hardened and linear ways to assure the rigidity and accuracy.

Y-axis control further enhances multi-tasking live tooling capabilities and improves various machining precision.

With Y-axis travel 80 mm(=±40mm) , a wide variety of parts can be efficiently machined.

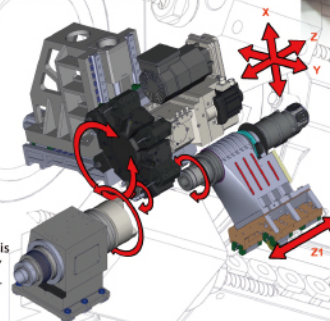

Linear Guideways

The guide ways are rectangular box section to maintain rigidity in prolonged operation. This high rigidity structure ensures high machine dynamics and superior machining accuracy.

Furthermore, all the axes equipped with C5 class high precision ball screw, mounted with double ballscrew support bearing (P4 class), assures high positioning accuracy and backlash free transmission.



Intention to make Engineering Technology

T6 Twin Compact

Feature :

- 6" chuck (Option : 8" chuck)
- 4,000 rpm high speed spindle
- 7.5 kw spindle power
- 12 station servo turret (Option : power turret - BMT55)
- Hydraulic tailstock or sub spindle for long work piece
- Sub spindle for back machining

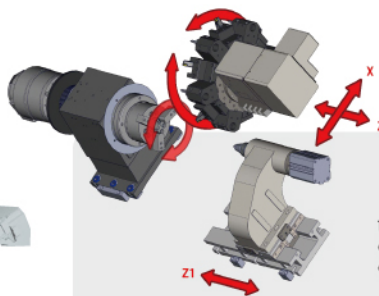

T6 compact

This compact machine will easily accomplish the demanding turning applications for mass production.

BMT Turret

The standard 12-station BMT turret allows this compact machine able to achieve the turning application effectively for mass production.

Furthermore, the power turret milling function is also provided for the customers who need more advanced application.

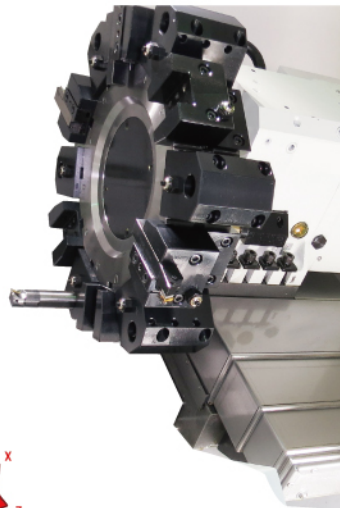

T6 Twin

On top of having T6 - Compact features, this model also packed with sub spindle for more back machining. Furthermore, with available live tooling, and C-axis capabilities milling, turning application can be completed in one single machine.

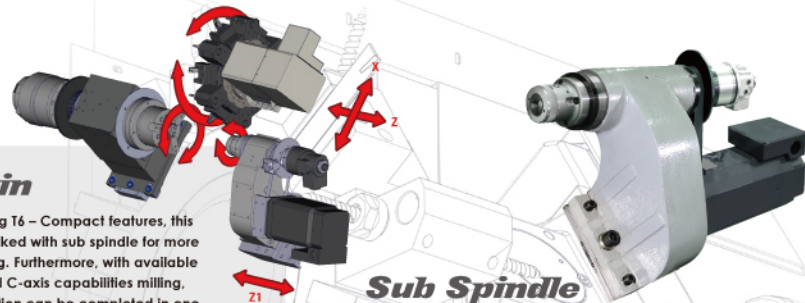

Sub Spindle Mitsubishi AC Servo 3.7 kw

Equipped with sub spindle, all the back machining is easily achieved.

Main Spindle Mitsubishi AC Servo 7.5 kw

The spindle is assembled and tested in a temperature controlled clean room, sealed, and requires no maintenance. The spindle housing is large, and symmetrically ribbed to allow heat dissipation and thermal stability.

Tailstock

For the long length parts, the hydraulic tailstock is also provided.



Intention to make Engineering Technology

Specification



Machine Type	T8 Hybrid-Y	T8 Hybrid	T8 Twin-Y	T8-Twin	T8-Classical	T6-Twin	T6-Compact
Mitsubishi Controller	M720	M720	M70	M70	M70	M70	M70
Main Spindle Capacity	Spindle bar capacity	65mm	65mm	65mm	65mm	42mm	42mm
	Swing over Bed	500.0 mm	500.0 mm	500.0mm	500.0mm	400.0mm	400.0mm
	Swing over cross slide	300.0 mm	300.0 mm	300.0mm	300.0mm	230mm	230mm
	Max. Turning length	350.0 mm	350.0 mm	350.0 mm	350.0 mm	300mm	300mm
	Main-Spindle Bore	66.0 mm	66.0 mm	66.0 mm	66.0 mm	44.0mm	44.0mm
	Spindle Speed	4000 rpm	4000 rpm	4000 rpm	4000 rpm	4000rpm	4000rpm
	Stant bed degree	75°	75°	75°	75°	75°	45°
Sub Spindle Capacity	Hydraulic pressure-mix / max	5/45 kgf/cm ²	5/45 kgf/cm ²	5/30 kgf/cm ²	5/30 kgf/cm ²	5/30 kg/cm ²	5/30 kg/cm ²
	Main-Spindle Chuck Size	KK6-185E-60B Collet/A2-6 Chuck	KK6-185E-60B Collet/A2-6 Chuck	KK6-185E-60B Collet/A2-6 Chuck	KK6-185E-60B Collet/A2-6 Chuck	KK6-173E-42B	KK6-173E-42B
	Sub-Spindle Chuck Size	KK5-173E-42B Collet/A2-5 Chuck	KK5-173E-42B Collet/A2-5 Chuck	KK5-173E-42B Collet/A2-5 Chuck	KK5-173E-42B Collet/A2-5 Chuck	KK4-163E-30B	KK5-173E-42B
	Sub-Spindle Bore	32.0 mm	32.0 mm	32.0 mm	32.0 mm	32mm	32mm
Travel & Feed	Sub-Spindle Speed Range	4000 rpm	4000 rpm	4000 rpm	4000 rpm	4000rpm	4000rpm
	X / Z Axis Travel	220.0mm/375.0mm	220.0mm/375.0mm	230.0mm/400.0mm	230.0mm/400.0mm	230.0mm/400.0mm	200.0mm/300mm
	X1 / Y1 / Z1 Axis Travel	470.0 mm/375.0mm/335.0 mm	470.0 mm/375.0mm/335.0 mm	Z1 / 385.0mm	Z1 / 385.0mm	Z1 / 300mm	Z1 / 300mm
Axes	Y Axis	80 mm±40mm	80 mm±40mm	80 mm±40mm	80 mm±40mm	80 mm±40mm	80 mm±40mm
	X / Z / X1 / Y1 / Z1 axis ball screw	Φ32 x P10	Φ32 x P10	X / Z Φ32 x P10	X / Z Φ32 x P10	X / Z Φ32 x P10	X / Z Φ32 x P10
	X / Z / X1 / Z1 axis linear guide way	35.0 mm	35.0 mm	X / Z 35.0mm	X / Z 35.0mm	X / Z 35.0mm	X / Z 35.0mm
Tooling system	X / Z / X1 / Y1 / Z1 axis rapid feed	30M/min	30M/min	30M/min	30M/min	30m/min	30m/min
	Channel 1						
	System	BMT-55 Turret	BMT-55 Turret	BMT-55 Turret	BMT-55 Turret	BMT-55 Turret	BMT-55 Turret
	No. of tools	12 (including OD / ID / Live)	12 (including OD / ID / Live)	12 (including OD / ID / Live)	12 (including OD / ID / Live)	Servo Turret 12 tools	Servo Turret 12 tools
	Tool holder	□25mm □25mm / 32mm	□25mm □25mm / 32mm	□25mm □25mm / 32mm	□25mm □25mm / 32mm	□25mm □25mm	□25mm □25mm
	Channel 2						
	System	Gantry	Gantry	---	---	---	---
Motor	No. of tools	OD x 5 ID x 9 Live x 12 tools	OD x 5 ID x 9 Live x 12 tools	---	---	---	---
	B axis(option accessory)	360° free angle	360° free angle	---	---	---	---
	Tool holder	□20mm □20mm	□20mm □20mm	---	---	---	---
	Main Spindle Motor	Mitsubishi AC Servo 11kw	Mitsubishi AC Servo 11kw	Mitsubishi AC Servo 11kw	Mitsubishi AC Servo 11kw	Mitsubishi AC Servo 11kw	Mitsubishi AC Servo 7.5KW
	Sub Spindle Motor	Mitsubishi AC Servo 5.5kw	Mitsubishi AC Servo 5.5kw	Mitsubishi AC Servo 3.7kw	Mitsubishi AC Servo 3.7kw	---	---
Positioning	X/Z axis Servo motor	Mitsubishi AC Servo 1.5kw(B) / 1.5kw	Mitsubishi AC Servo 1.5kw(B) / 1.5kw	Mitsubishi AC Servo 1.5kw(B) / 1.5kw	Mitsubishi AC Servo 1.5kw(B) / 1.5kw	X / Z Mitsubishi AC Servo 1.5kw	X / Z Mitsubishi AC Servo 1.5kw
	X1/Y1/Z1 axis Servo motor	Mitsubishi AC Servo 1.5kw / 1.5kw(B) / 1.5kw	Mitsubishi AC Servo 1.5kw / 1.5kw(B) / 1.5kw	Z1 axis / Mitsubishi AC Servo 1.5kw	Z1 axis / Mitsubishi AC Servo 1.5kw	Z1 = Mitsubishi AC Servo 1.0kw	---
	Chip conveyor motor	1/2 hp	1/2 hp	1/4 hp	1/4 hp	1/4HP	1/4HP
Coolant System	Hydraulic pump motor	1 hpx2	1 hpx2	2 hp	2 hp	1HP	1HP
	Positioning	0.001mm	0.001mm	0.005mm	0.005mm	0.001mm	0.001mm
	Coolant Motor Type	max.pressure : 5bar(4.6kg/cm ²) flow : 75L / min	max.pressure : 5bar(4.6kg/cm ²) flow : 75L / min	max.pressure : 5bar(4.6kg/cm ²) flow : 75L / min	max.pressure : 5bar(4.6kg/cm ²) flow : 75L / min	max.pressure : 5bar(4.6kg/cm ²) flow : 75L / min	max.pressure : 5bar(4.6kg/cm ²) flow : 75L / min
Lubrication System	Hydraulic Motor Type	max.pressure : 25bar(55kg/cm ²) flow : 30L / min	max.pressure : 25bar(55kg/cm ²) flow : 30L / min	max.pressure : 25bar(55kg/cm ²) flow : 30L / min	max.pressure : 25bar(55kg/cm ²) flow : 30L / min	---	---
	Coolant Tank Capacity	240L	240L	240L	240L	142L	142L
Machine size	Tank capacity	2 L	2 L	2 L	2 L	2L	2L
	Pump pressure	15 kgf / cm ²	15 kgf / cm ²	15 kgf / cm ²	15 kgf / cm ²	15 kgf / cm ² (100cc/min)	15 kgf / cm ² (100cc/min)
	Length without / with chip conveyor	2850mm/3550 mm	2850mm/3550 mm	2450mm/3350 mm	2450mm/3350 mm	2600mm / 3200mm	2600mm / 3200mm
Machine size	Machine Width / Height	1950mm / 1970 mm	1950mm / 1970 mm	1650mm / 1750 mm	1650mm / 1750 mm	1300 / 1860mm	1300 / 1860mm
	Machine Weight	6100 kg	6100 kg	5900 kg	5900 kg	3500 kg	3000 kg



Fanuc available (option)

Specification