

TMT2000 series

Multi-tasking Turning Center

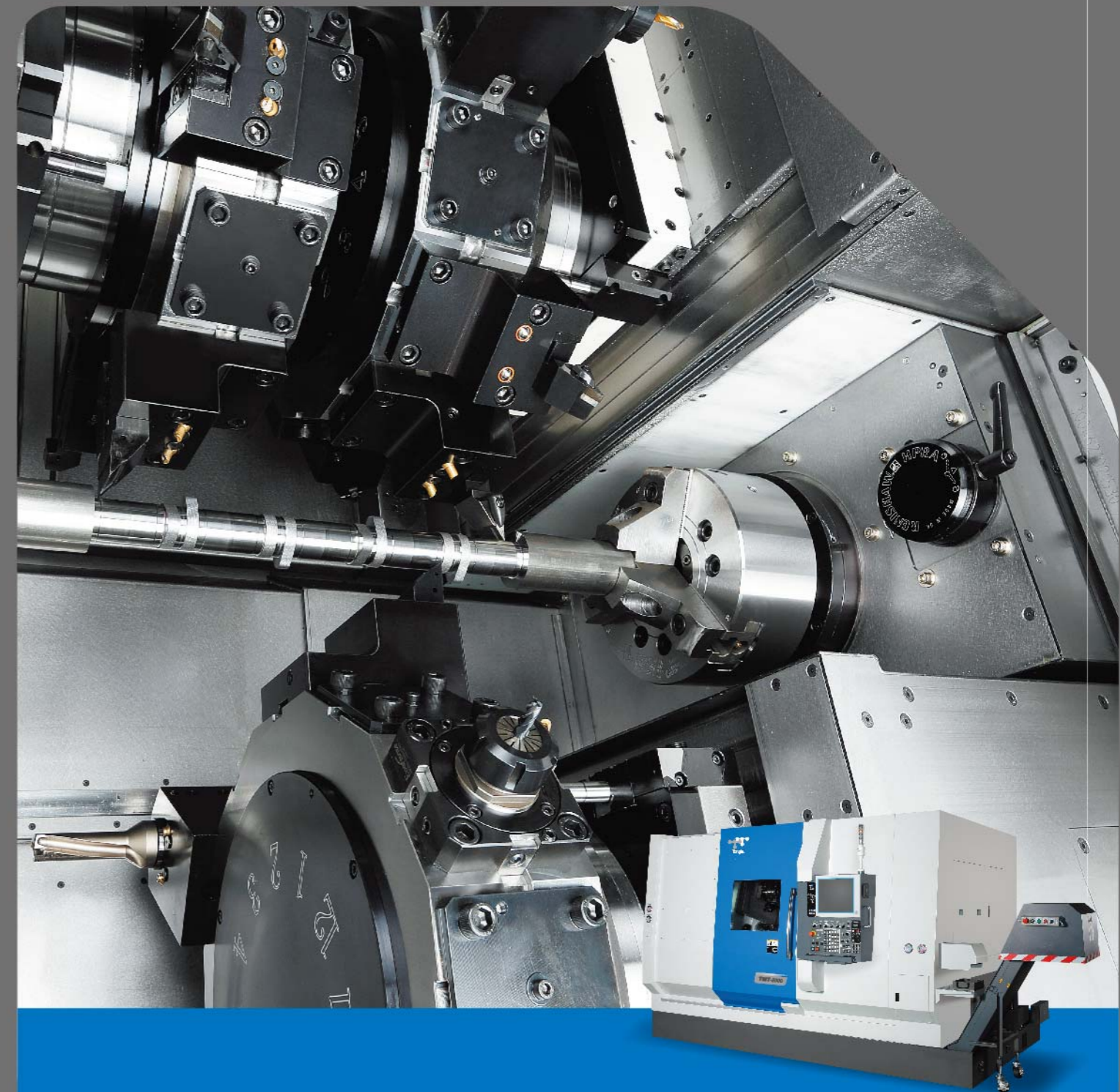

Tongtai Tongtai Machine & Tool Co., Ltd.

NO.3, LUKE 3rd. RD., LUZHU DISTRICT, KAOHSIUNG CITY, 82151, TAIWAN.

TEL: 886-7-9761588

FAX: 886-7-9761589/886-7-9761590

Website: <http://www.tongtai.com.tw>

Taoyuan Office	TEL: 886-3-4551399	FAX: 886-3-4559730
Taichung Office	TEL: 886-4-23589600	FAX: 886-4-23589993
Tongtai Seiki U.S.A. Inc.	TEL: 1-845-2675500	FAX: 1-845-2675546
Tongtai Machine & Tool Japan Co., Ltd.	TEL: 81-4-71438355	FAX: 81-4-71438360
Tongtai Seiki Vietnam Limited	TEL: 84-435112529	
Europe Office	TEL: 31-161-454639	FAX: 31-161-454768
Thailand Office	TEL: 66-2-7443440	FAX: 66-2-3986518
Indonesia Office	TEL: 62-21-45850521	FAX: 62-21-45840522
Malaysia Office	TEL: 60-3-78456815	FAX: 60-3-78456851



SHUZHOU TONG-YU MACHINE & TOOL CO., LTD.

TEL: 86-512-63430168

FAX: 86-512-63431622

E-mail: sales@tong-yu.com.cn

Wuhan Office	TEL: 86-27-59409109	FAX: 86-27-59409110
Shanghai Office	TEL: 86-21-24208138	FAX: 86-21-34073262
Chongqing Office	TEL: 86-23-67865925	FAX: 86-23-67867717
Guangzhou Office	TEL: 86-755-27222119	FAX: 86-755-27222115
Tianjin Office	TEL: 86-22-24417640	FAX: 86-22-24416738
Shenyang Office	TEL: 86-24-24142968	FAX: 86-24-24115782

TMT2000 series

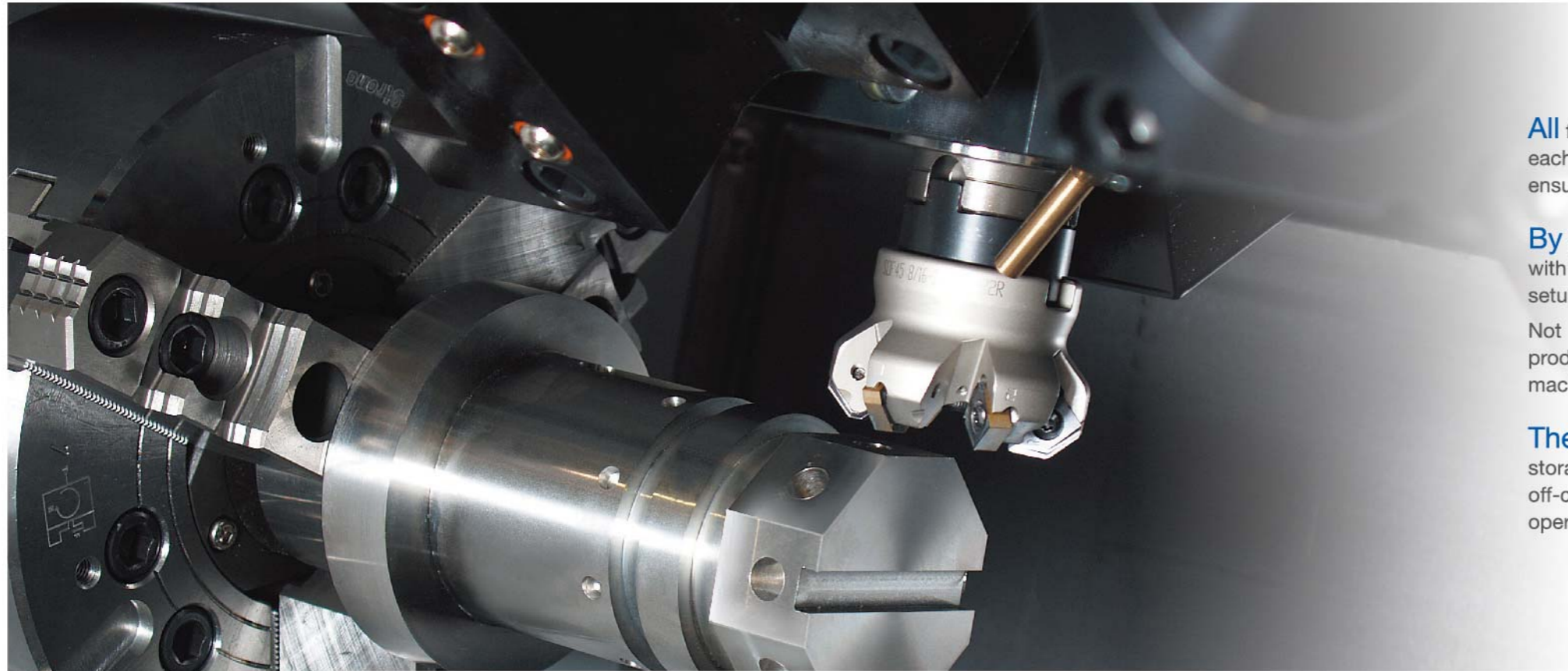

All features including symmetrical saddle design, X/Y/Z axes perpendicular to each other and really linear Y axis, which make servo compensation possible, ensure excellent positioning accuracy.

By basic structure with main spindle and sub-spindle plus two or three turrets with Y axis, most of complex parts are possible to be finished in one machine setup.

Not only for the different workpiece and lot sizes but also for the mass production, TMT2000 series of modular design concept will create the best machining solution with best investment combination.

The automation is easily fulfilled by a bar feeder or a robotic arm with parts storage. The compound machine functions including turning, milling and even off-center machining plus the automation solution make long-term manless operations possible and guarantee investment return.

CONTENTS

- 03 Machining example
- 05 Machining ability
- 06 Machining accuracy
- 07 Machining applications
- 08 Main structure
- 11 Operation & Maintenance
- 12 Peripheral accessories
- 13 Automation solution
- 14 3D Interference protection
- 15 Diagrams
- 21 Standard/optional accessories
- 22 Specifications



Machining example

Camshaft

Material : S45C
 Raw material size : Ø50 mm×L600 mm
 Finished size : Ø32 mm×L365 mm

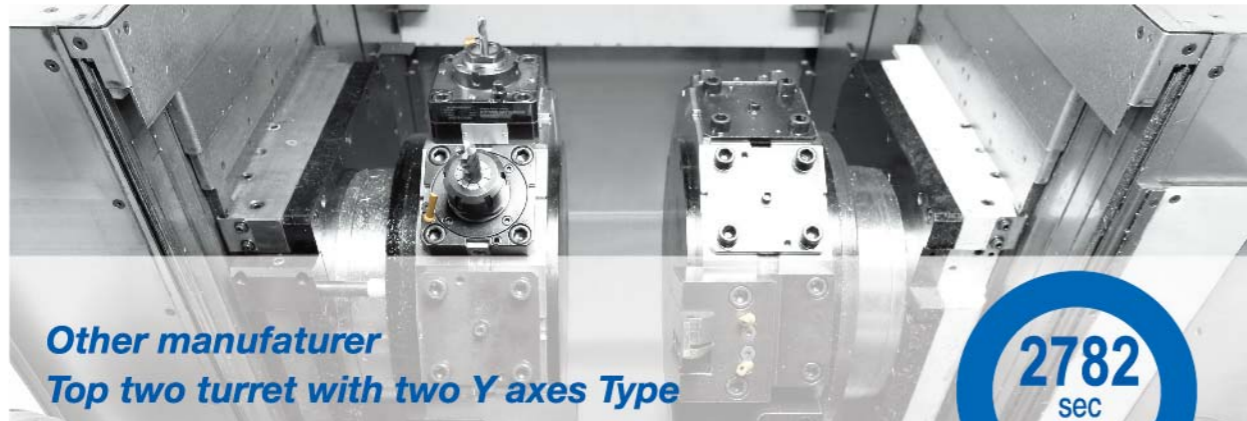

Other manufacturer
 Top two turret with two Y axes Type

2782
 sec

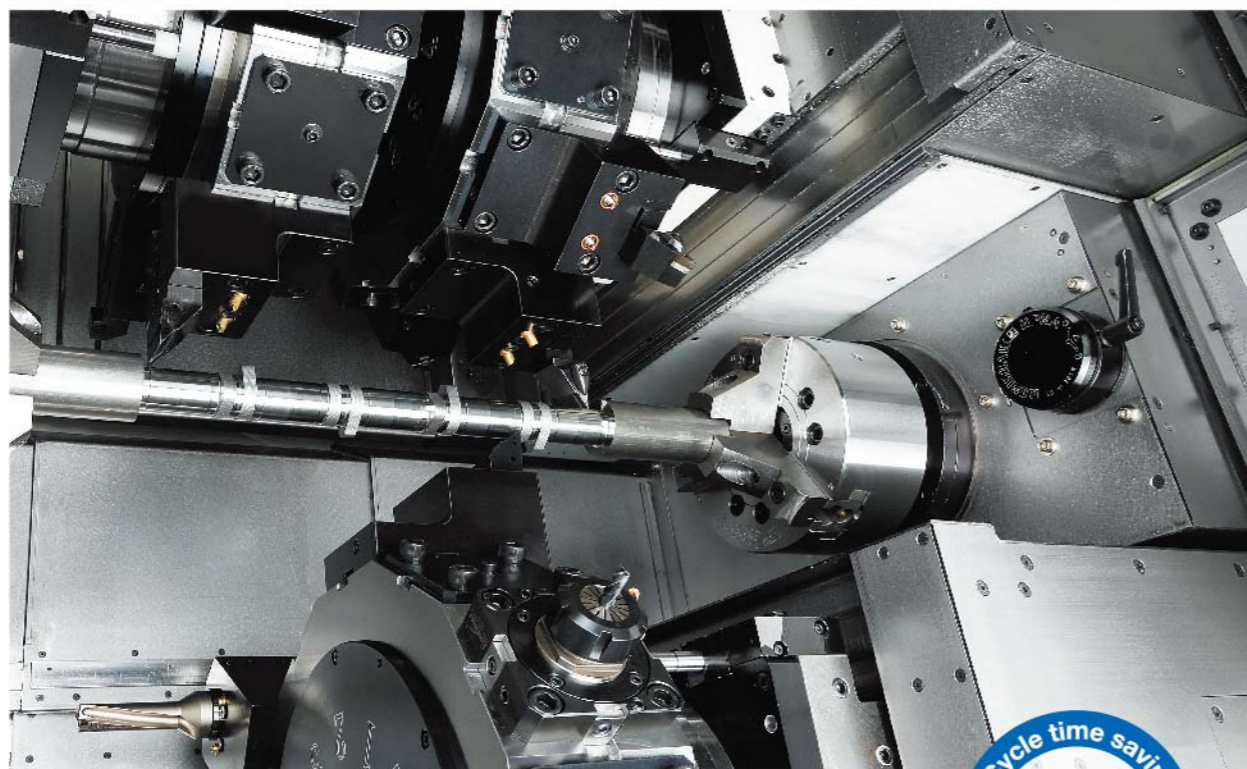

TMT2000-T3Y2 1398 sec
 TMT2000-T2Y1 2236 sec

50%
 Cycle time saving

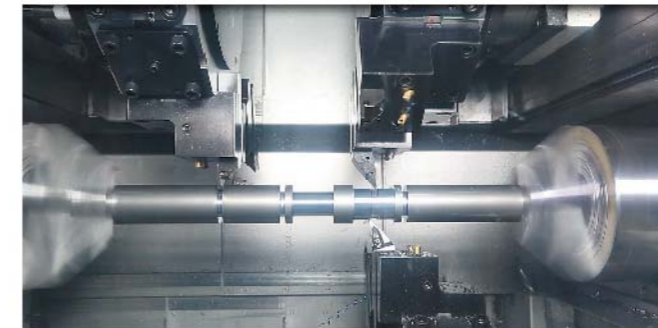

Through multi-tasking function, three turrets are able to process cutting and grooving simultaneously. The multi-tasking function can improve the machining efficiency and speed up the investment return.



Chatter happens when a shaft has higher slender ratio because of the deflection during machining. Balanced machining is an excellent solution to solve the chatter quickly and effectively.

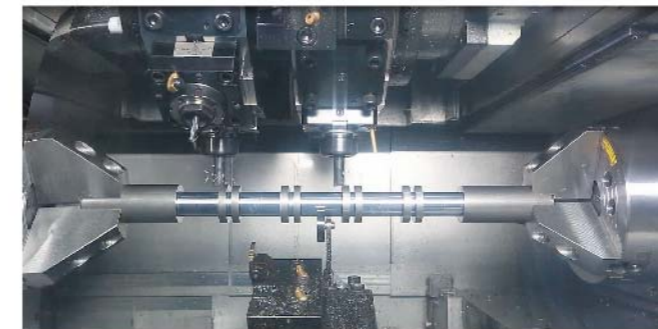

The lower turret provides the support function for long shaft to decrease deflection. Through synchronous and composite function, the machining solution become more flexible and help operators to achieve the objective faster and safer.

Pulley shaft of CVT system

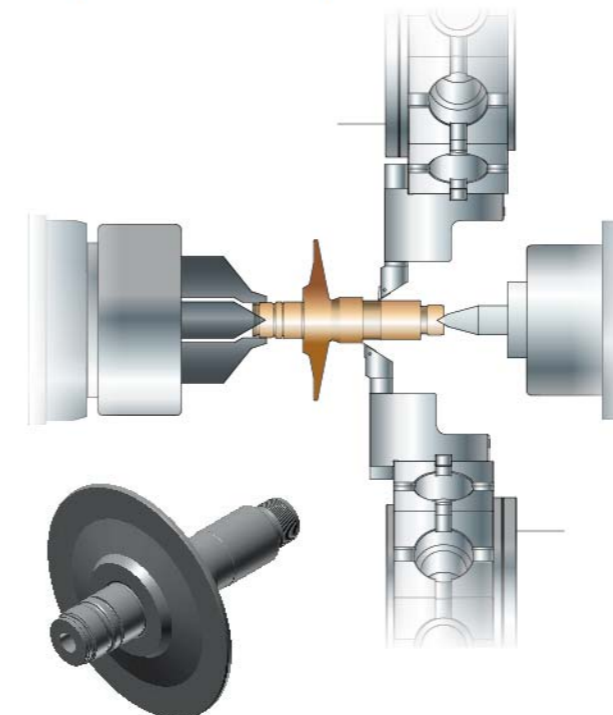

Machining methods on the 1st turret (7 tools)

1	O.D. and end face roughing
2	O.D. and end face finishing
3	Groove roughing
4	Groove finishing
5	Keyway milling(Ø10×R0.3)
6	Chamfering(Ø10×90°)

Machining methods on the 2nd turret (5 tools)

1	O.D. and end face roughing
2	O.D. and end face finishing
3	Taper face finishing
4	Threading(M30×P1.25)
5	Keyway milling (Ø10×R0.3)

Machining ability

Turning Material : S45C

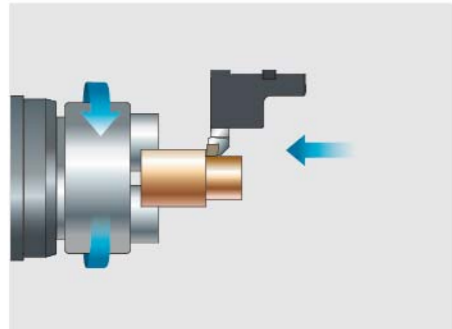

O.D. turning	
Material removal rate	330 cm ³ /min
Cutting depth	5 mm
Spindle speed	763 rpm
Feedrate	0.5 mm/rev
Cutting speed	120 m/min

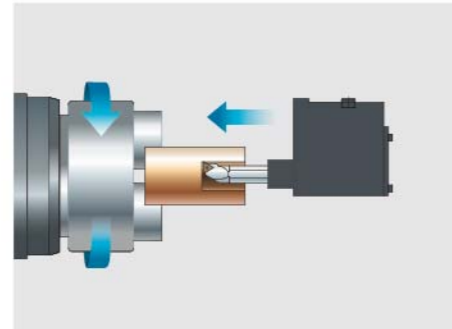

I.D. turning	
Material removal rate	303 cm ³ /min
Cutting depth	5 mm
Spindle speed	637 rpm
Feedrate	0.55 mm/rev
Cutting speed	120 m/min



Grooving	
Cutting width	8 mm
Spindle speed	637 rpm
Feedrate	0.1 mm/rev
Cutting speed	120 m/min

Milling Material : S45C

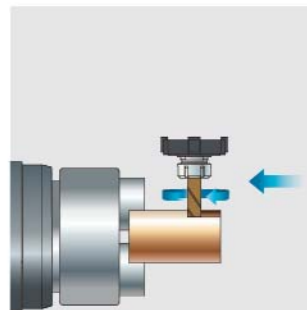

End milling	
Material removal rate	96 cm ³ /min
Tool	end mill Ø20 mm (4 teeth)
Spindle speed	500 rpm
Feedrate	0.1 mm/rev/tooth
Cutting speed	200 mm/min
Cutting width	20 mm
Cutting depth	24 mm

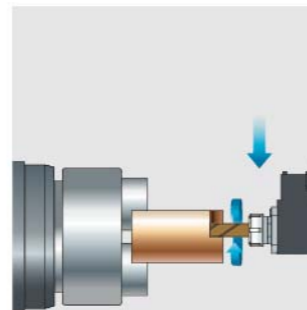

End milling	
Material removal rate	96 cm ³ /min
Tool	end mill Ø20 mm (4 teeth)
Spindle speed	500 rpm
Feedrate	0.1 mm/rev/tooth
Cutting speed	200 mm/min
Cutting width	20 mm
Cutting depth	24 mm

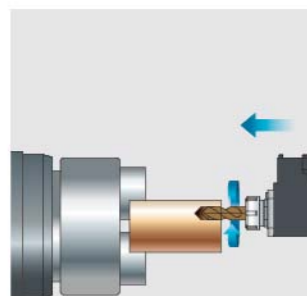

Drilling	
Material removal rate	25 cm ³ /min
Tool	drill Ø20 (2 teeth)
Spindle speed	398 rpm
Feedrate	0.2 mm/rev
Cutting speed	25 m/min

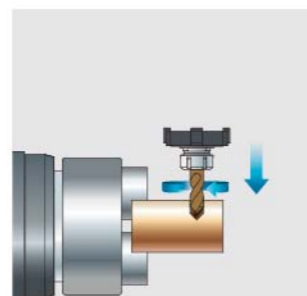

Drilling	
Material removal rate	25 cm ³ /min
Tool	drill Ø20 (2 teeth)
Spindle speed	398 rpm
Feedrate	0.2 mm/rev
Cutting speed	25 m/min

Machining accuracy

Turning accuracy

		Roundness	Cylindricity	Roughness
Material	Brass	0.7 μm	5 μm	0.28 μm Ra
Tool	Diamond cutting tool			
Turning diameter	60 mm			
Spindle speed	3000 rpm			
Feedrate	0.05 mm/rev			

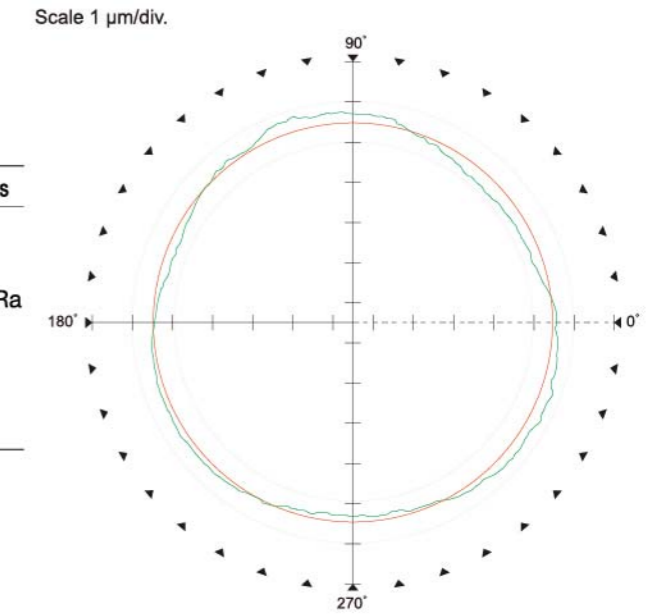

* The above data is measured in-house. The test result may not be obtained due to differences cutting conditions and environment conditions.

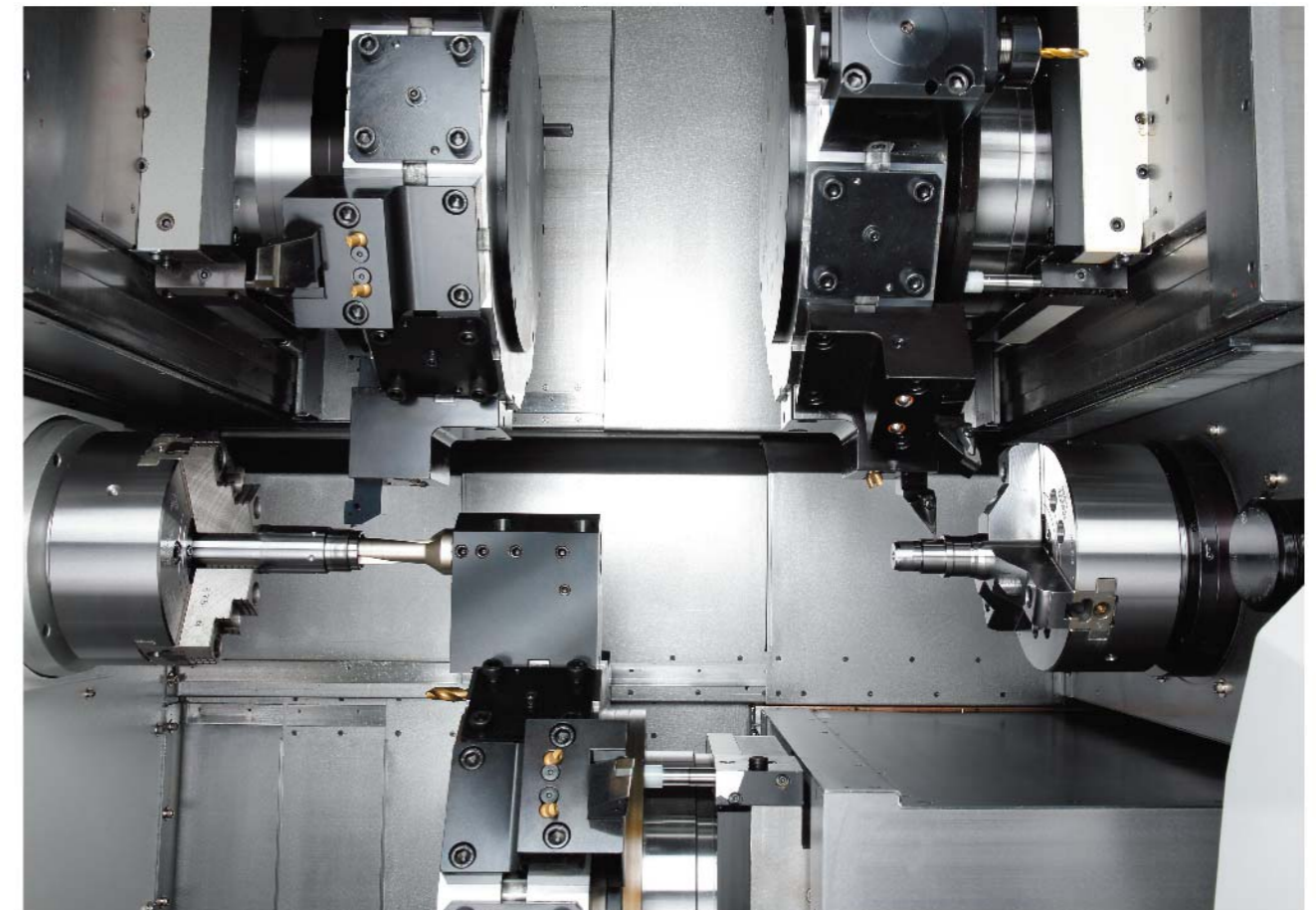

Machining applications

Main structure

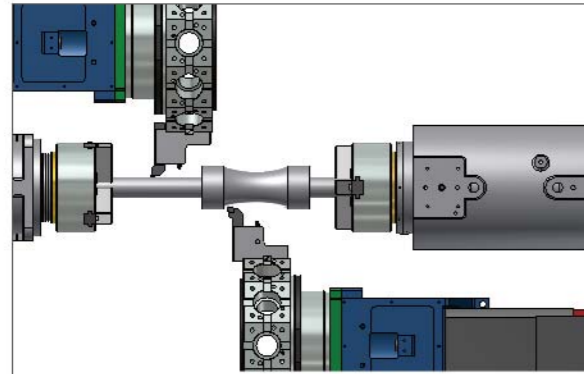

The upper and lower turrets are turning the part together to save cycle time.

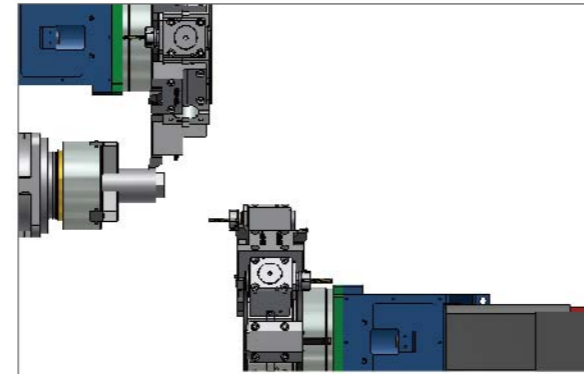

The machining process is continued by one turret after the other to save tool changing time.

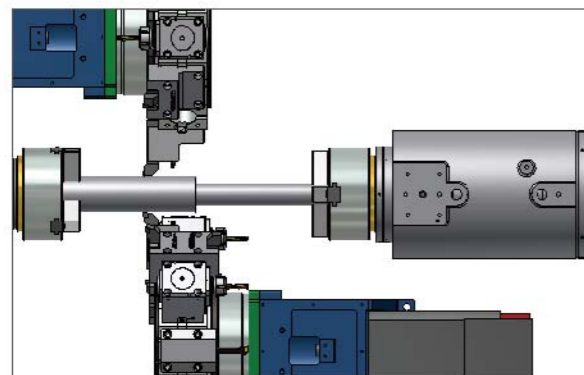

The reaction force against each other may reduce the vibration when both upper and lower turrets are processing simultaneously.

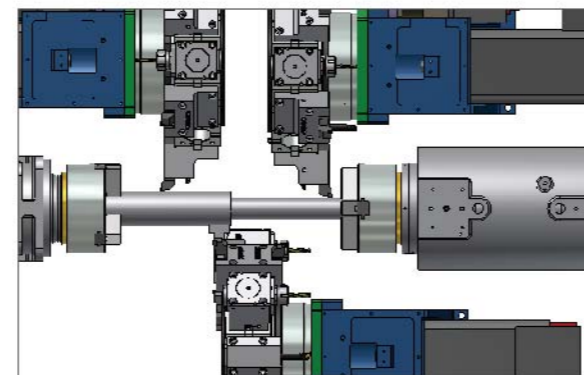

The lower turret can be used as a steady rest to avoid vibration for the long shaft machining.

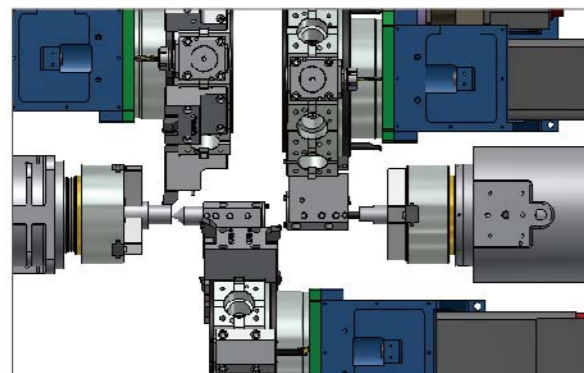

The lower turret can be used as a center to support the shaft.

Travel

X1/X2/X3 axis	205 mm
Y1/Y3 axis	102(±51) mm
Z1/Z2 axis (Two turrets)	600/600 mm
Z1/Z2/Z3 axis (Three turrets)	440/600/440 mm
B axis	680 mm

Rapid traverse

X1/X2/X3 axis	30 m/min
Y1/Y3 axis	15 m/min
Z1/Z2/Z3 axis	36 m/min
B axis	30 m/min

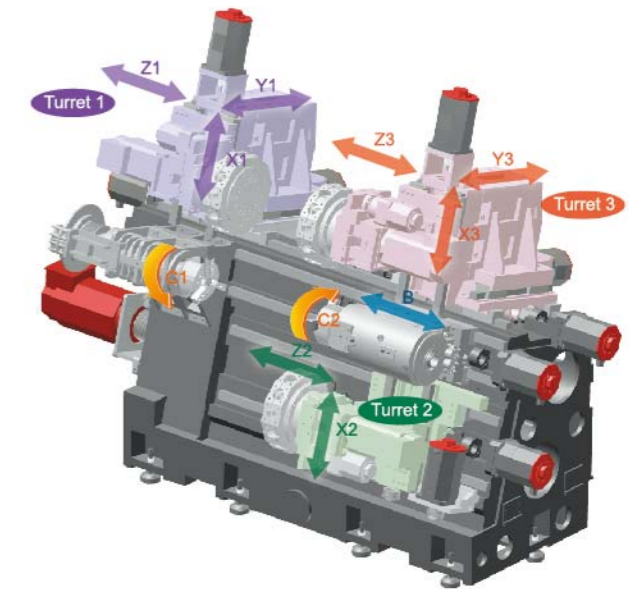

Linear Y axis structure

Different from simulated Y axis, the real linear Y axis provides high machining accuracy by its straightness and positioning accuracy. Through high rigid saddle design guarantee precise machining performance.

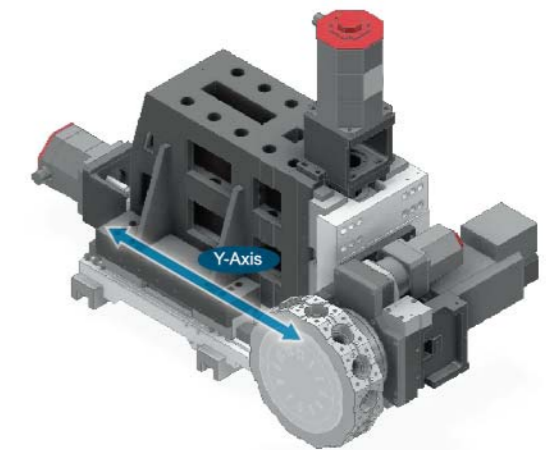

Working area

Distance between spindle noses	986 mm
Max. tool length of reverse tool	125 mm(T1,T3) 115 mm(T2)

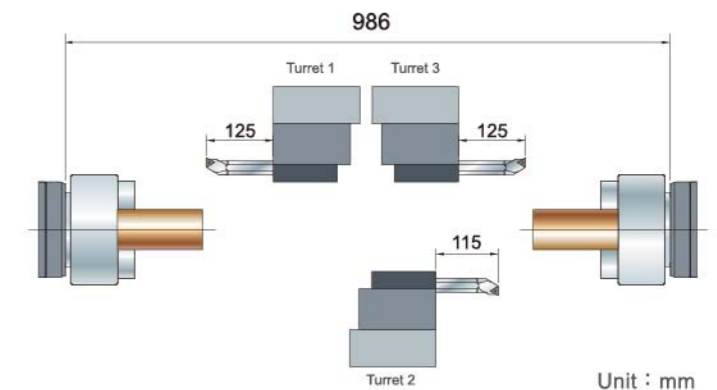

Main structure

Spindle

	Spindle 1	Spindle 2
Chuck size	8"	8"
Bar capacity	Ø65 mm Ø51 mm(Spindle speed 6000 rpm)	Ø51 mm
Max. spindle speed	4500 rpm 6000 rpm(Collet chuck only)	6000 rpm
Spindle motor	15/11 kW	18.5/11 kW
Driving method	Belt-drive	Built-in motor

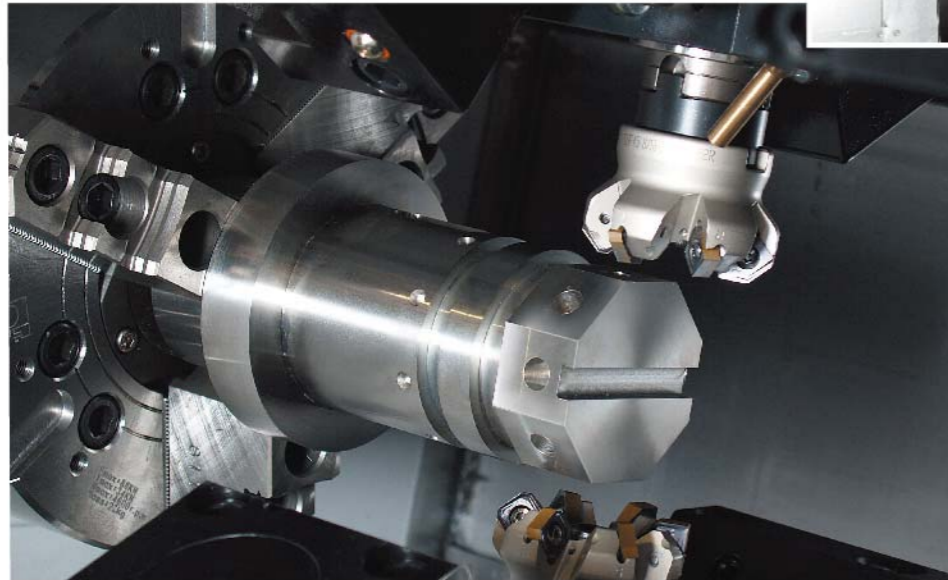

Sub-spindle cooler

With synchronous temperature control, the spindle cooler prevents sub-spindle from thermal distortion. This ensures high precision machining for long-term operation.

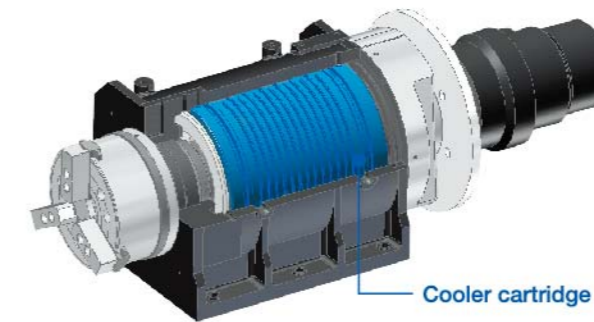

Cooler cartridge



Turret

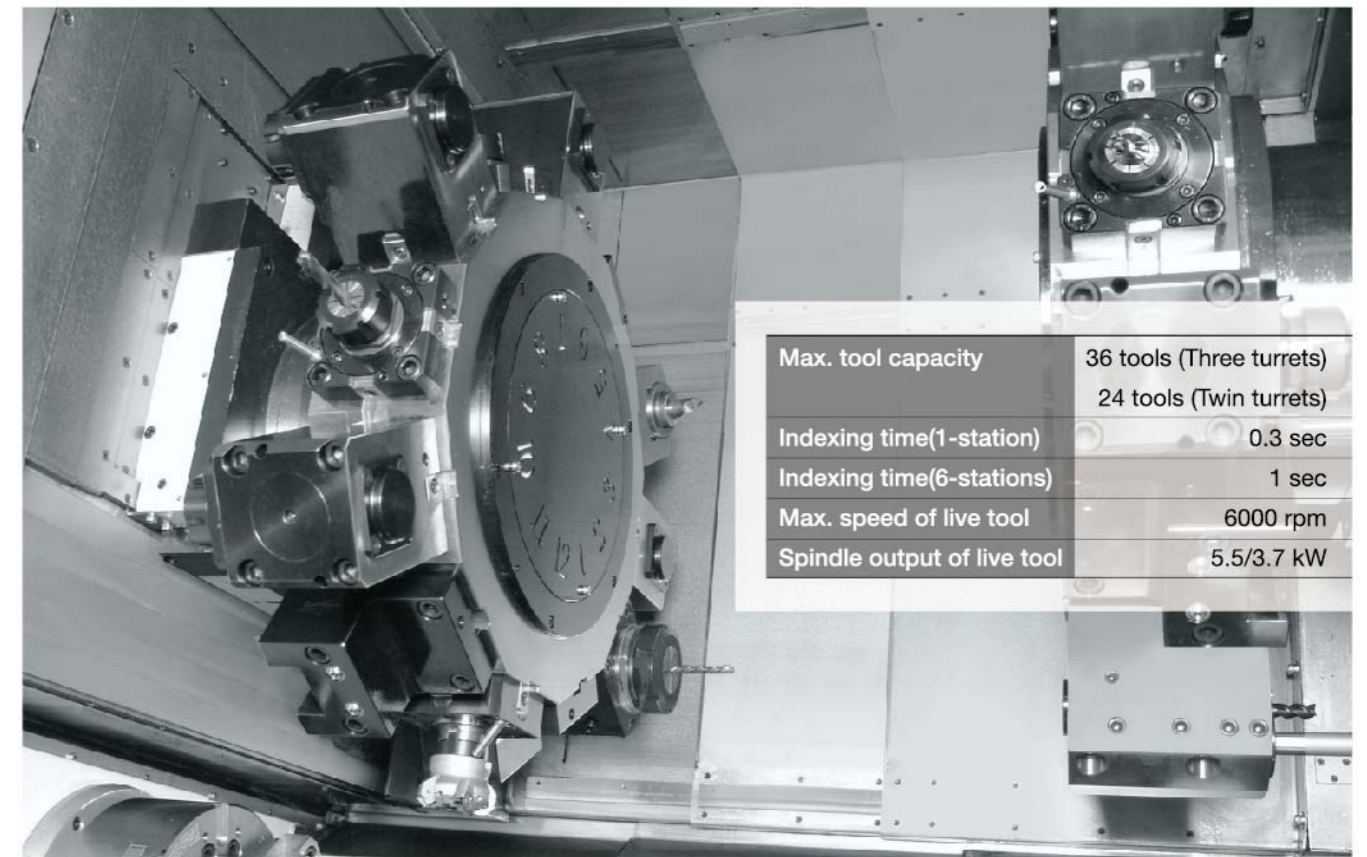

Max. tool capacity	36 tools (Three turrets) 24 tools (Twin turrets)
Indexing time(1-station)	0.3 sec
Indexing time(6-stations)	1 sec
Max. speed of live tool	6000 rpm
Spindle output of live tool	5.5/3.7 kW

Spindle/Sub-spindle CS axis with brake unit

The CS axis is fed back by a rotary encoder with multi-points positioning function. The minimum indexing increment of 0.001 degrees allows various machining needs with different angles.

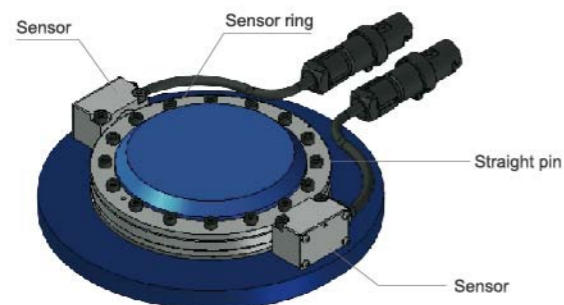

Operation

Swivel-type operation panel



The operation panel is able to swivel from 0 to 90 degrees, which improves visibility during operation.

Accessibility

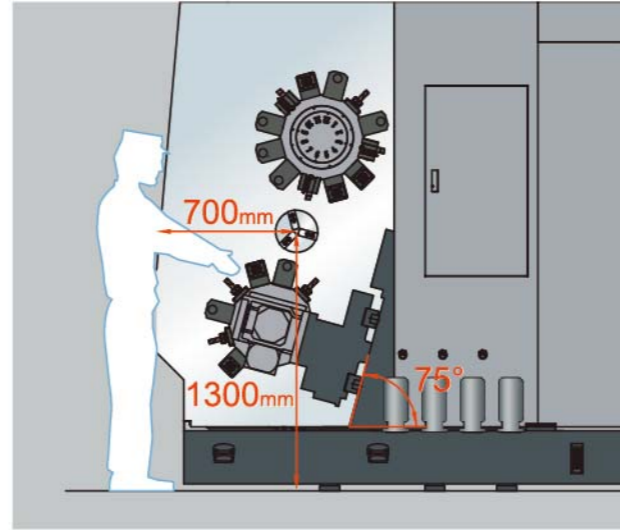

The access to spindles or turrets is short and comfortable to operator.

Door opening width

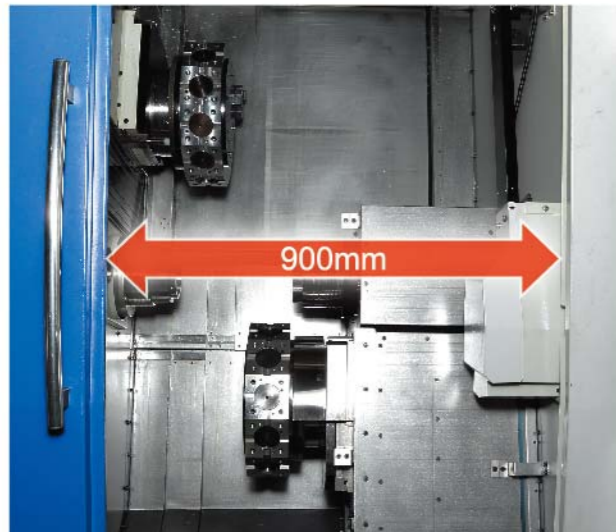

The wide door opening makes machine operation and maintenance more convenient.

Easier daily maintenance



Through centralized management of pneumatic solenoid and lubricant pump, daily maintenance becomes easy.

Peripheral accessories

Chip conveyor

According to different materials and chip size, Tongtai provides various chip conveyors for the best chip disposal.

○ : Suitable X : Non-suitable

Specification	Steel			Cast iron	Aluminum/Non-ferrous metal		
	Long/ Curl chips	Short chips	Powder chips	Short chips	Long/ Curl chips	Short chips	Powder chips
Hinge type	○	×	×	×	○	×	×
Scraper type	×	○	○	○	×	○	○
Magnetic scraper type	×	○	○	○	×	×	×
Drum type	×	○	○	○	×	○	○
Integrated type	○	○	○	○	○	○	○

Short chips : Chips shorter than 60 mm or ball type chips smaller than Ø40 mm.
Curl long chips : Chips' length is longer than short ones.



Coolant tank capacity
710 L(80% full)

Manual tool presetter (Optional)



Disc type oil skimmer (Optional)

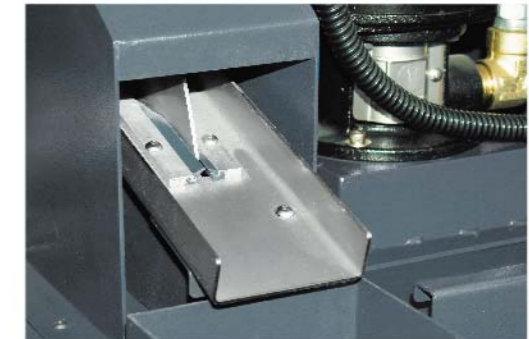

Oil mist collector (Optional)



Automation solution

3D Interference protection

Bar feeder & part catcher

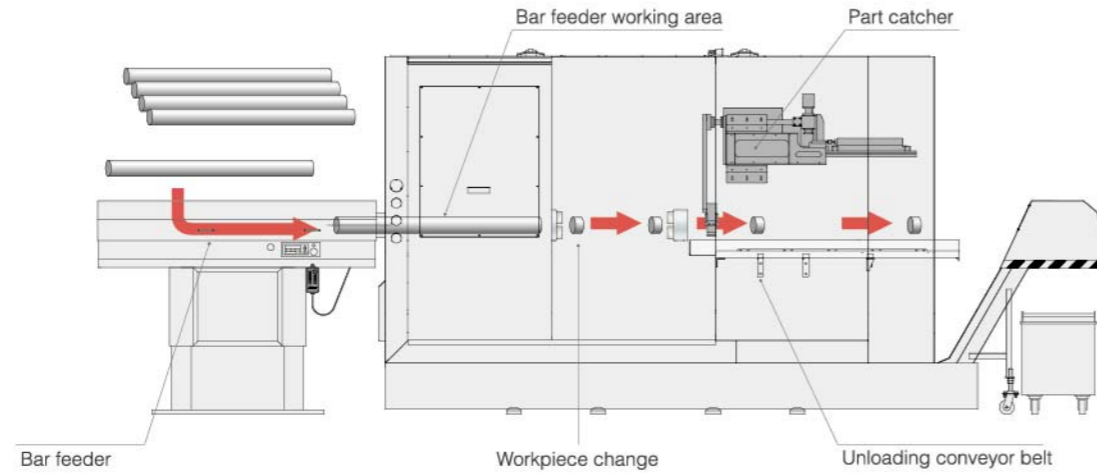

Gantry type robot system & part storage system

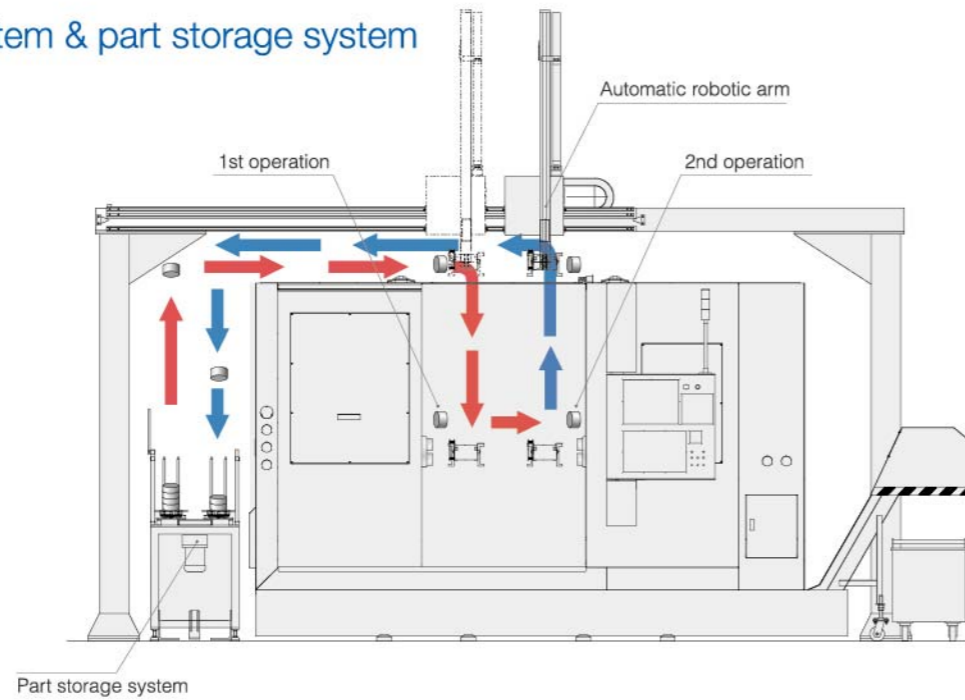

		Item	Unit	Specification
Robotic arm	Max. load		kg	5(x2)
	Rapid traverse	X-axis (equipped in the up side and the down side of arm)	m/min	120
		Z-axis (equipped in the right and the left side of machine)	m/min	120
Gripper	Type			Rotary gripper
	Workpiece size	Outer diameter	mm	Ø30~200
		Length	mm	10~150
		Weight	kg	5

Without interference protection system, complex machine configurations operated in manual mode can result in collisions with tools and workpieces. With Tongtai's 3D interference protection system and cutting simulation function, operators can guarantee collision free setups by verifying through prerun testing.

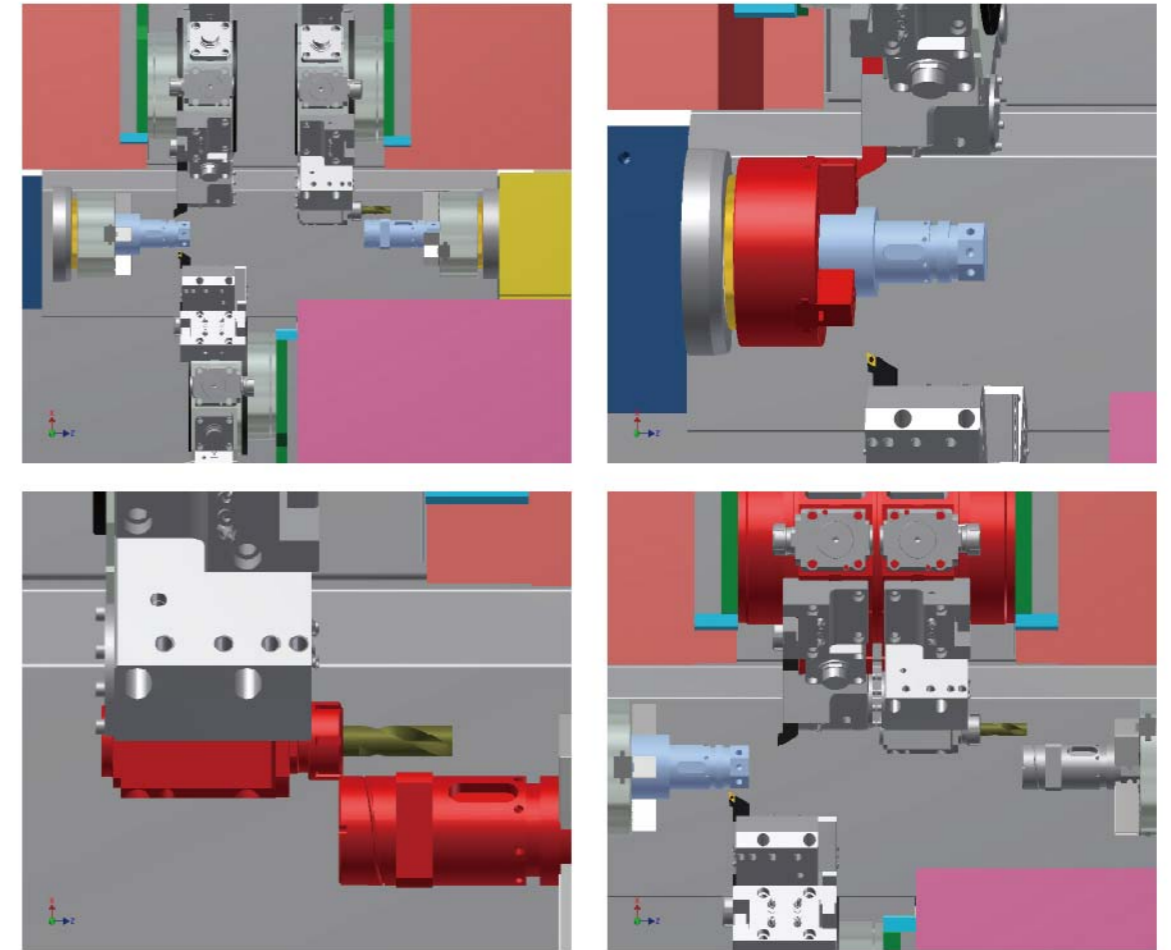

Characteristics

- Improves user interface with simple parameter setting procedures for tools, workpiece, chucks, jaws and fixtures.
- Checks for interference in 3D for machine cover, turrets, spindles, tools, workpieces, chucks, jaws and fixtures.
- Model data for machine is installed as standard.
- The machine will stop before collision when interference is detected in manual or in automatic mode.
- Advanced preview of turning/milling simulation and collision protection.
- Work piece change from main spindle to second spindle can be simulated and checked.
- During 3D interference check, cutting simulation shows how material is removed as machining proceeds.
- When the tool position is set accurately, the 3D cutting simulated machine part can be checked with theoretical 3D model without machining a real workpiece for process verification.

Spindle output and torque chart

Main spindle motor (Belt drive)

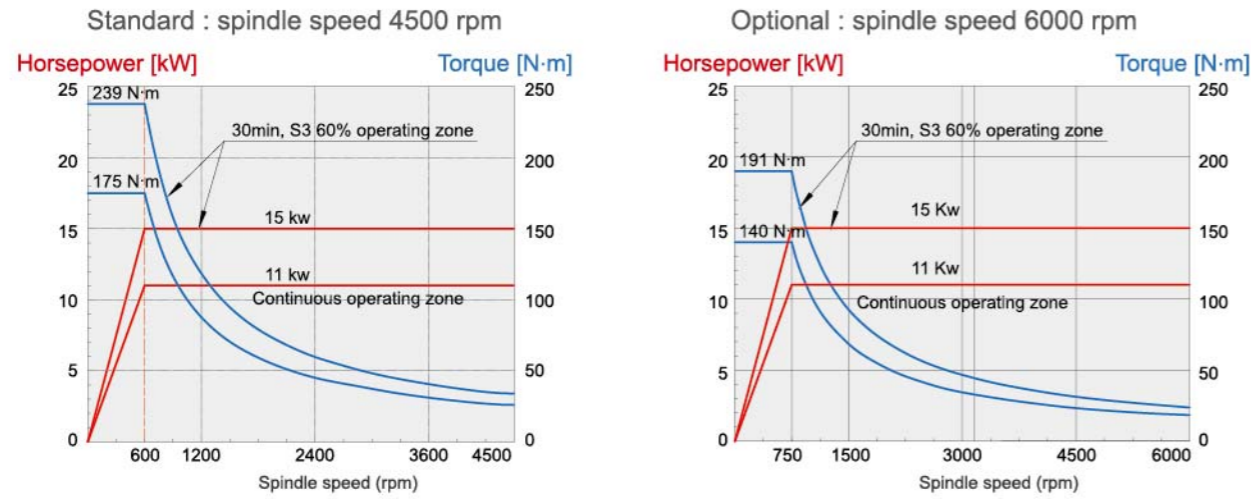

Sub-spindle motor (Built-in motor)

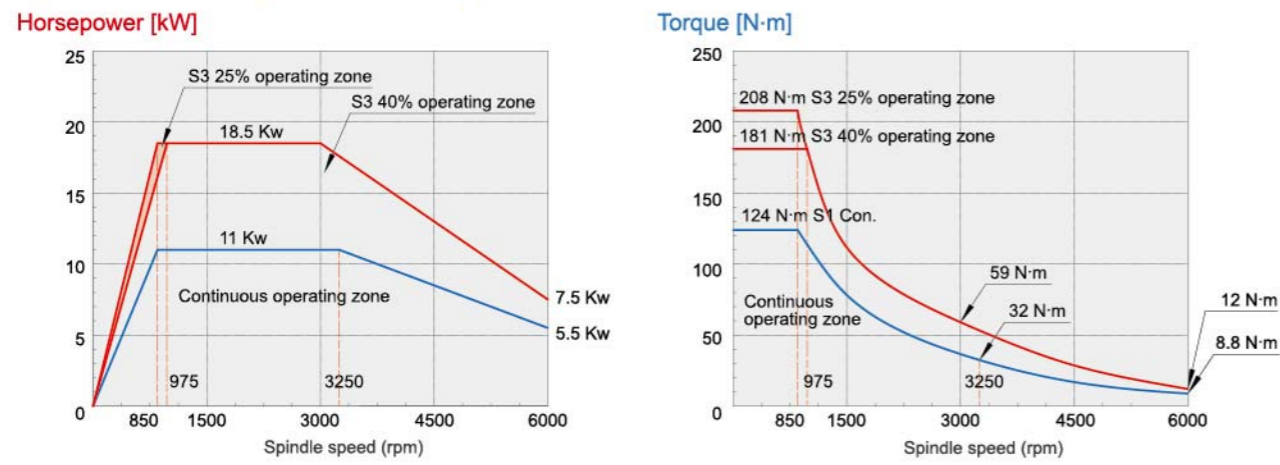

Live tool motor

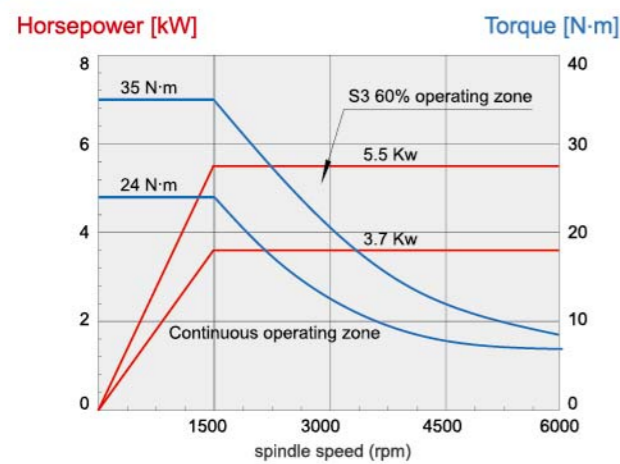

Tool system

BMT65

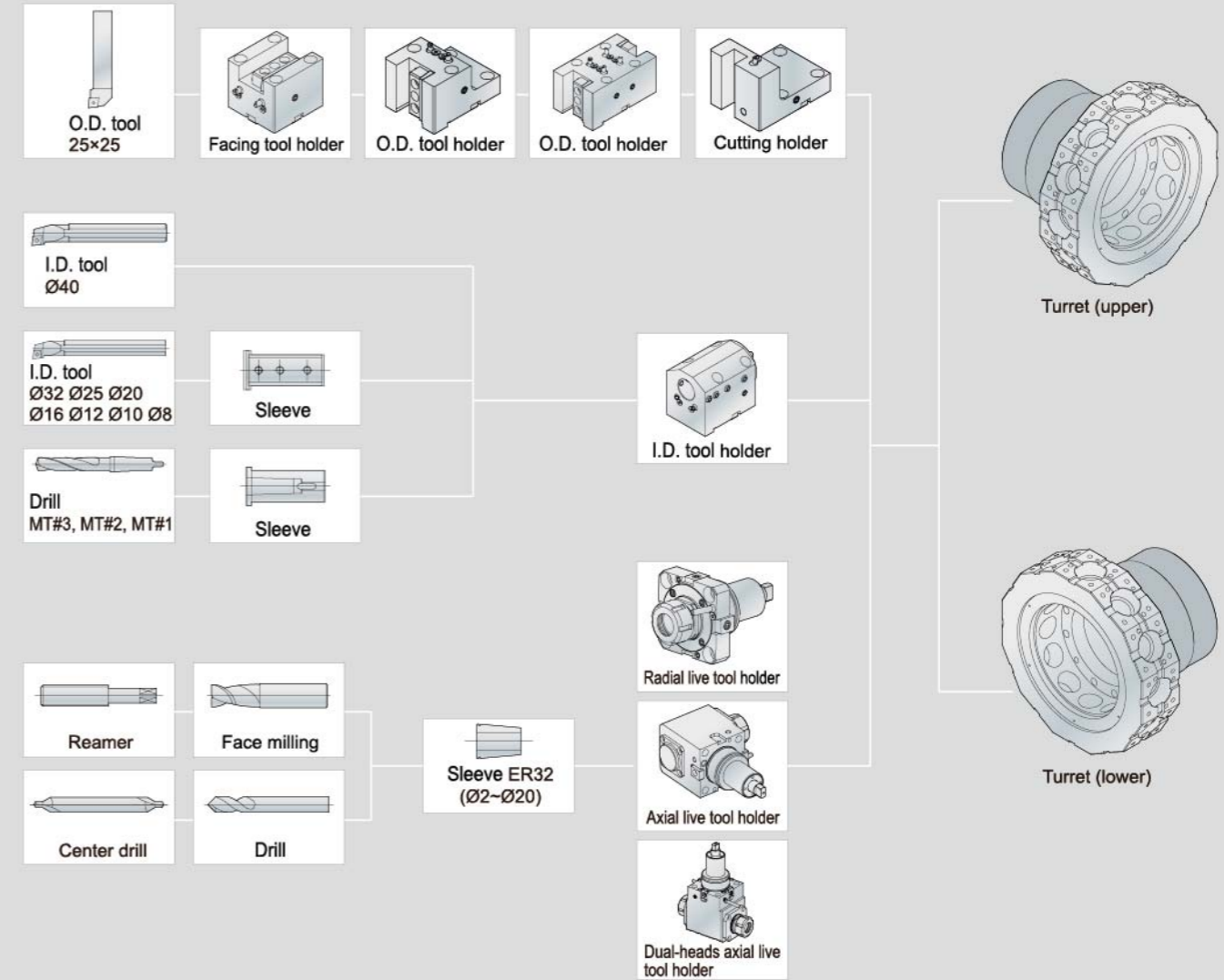

Unit : mm

	Turret 1	Turret 2	Turret 3
Center height of ID tool holder	85(Opt.100)	100	85(Opt.100)
Center height of axial live tool holder	85	100	85

Tool interference

(Turret 1) ID tool holder with center height 85 mm/(Turret 2) ID tool holder with center height 100 mm

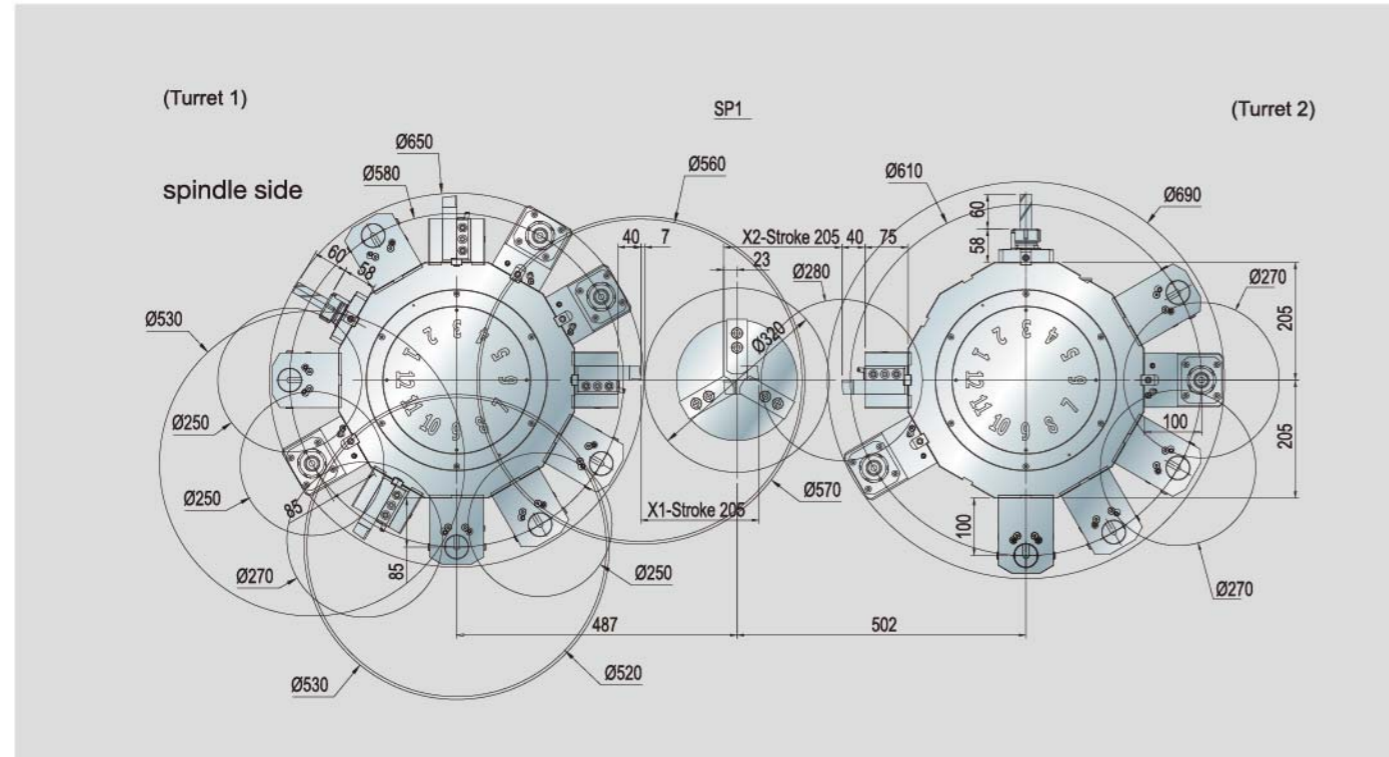

(Turret 3) ID tool holder with center height 85 mm/(Turret 2) ID tool holder with center height 100 mm

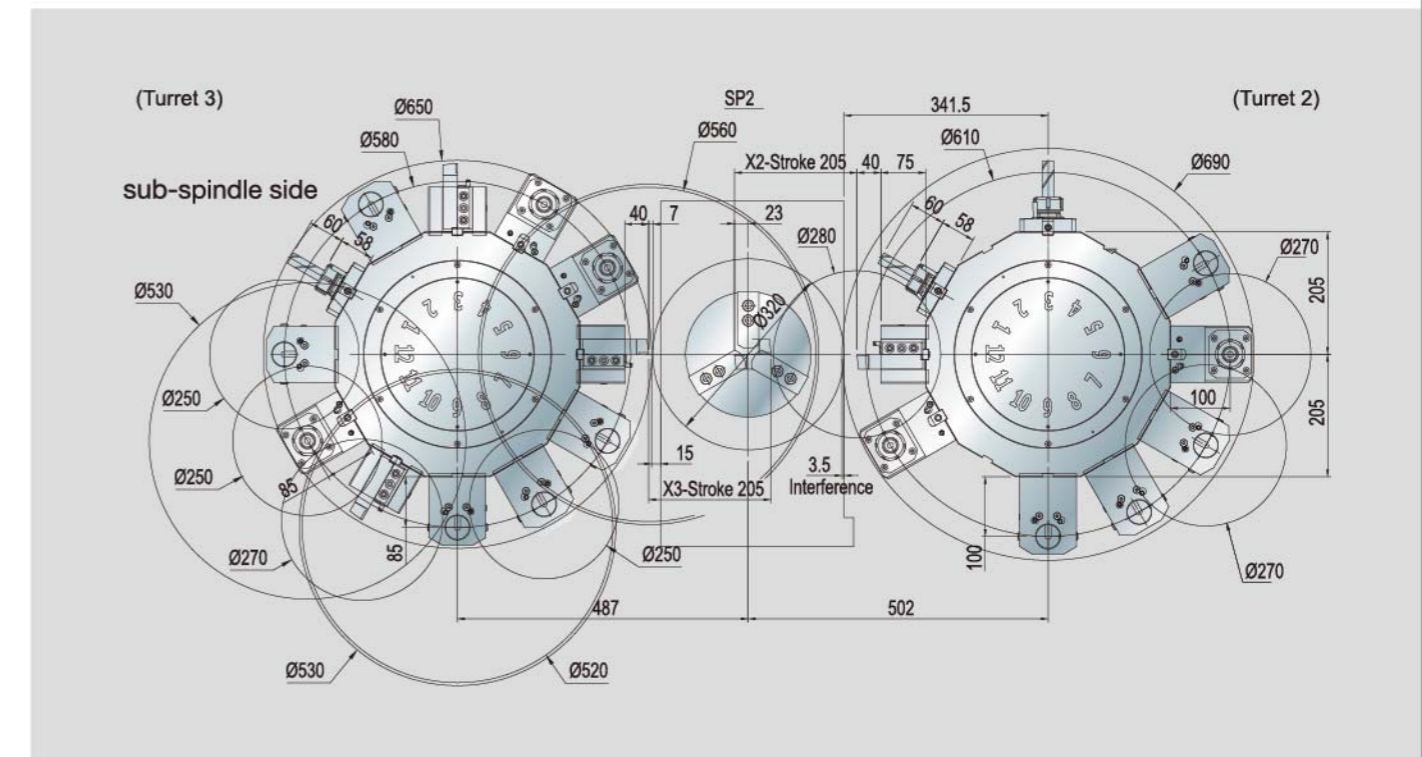

(Turret 1) ID tool holder with center height 100 mm/(Turret 2) ID tool holder with center height 100 mm

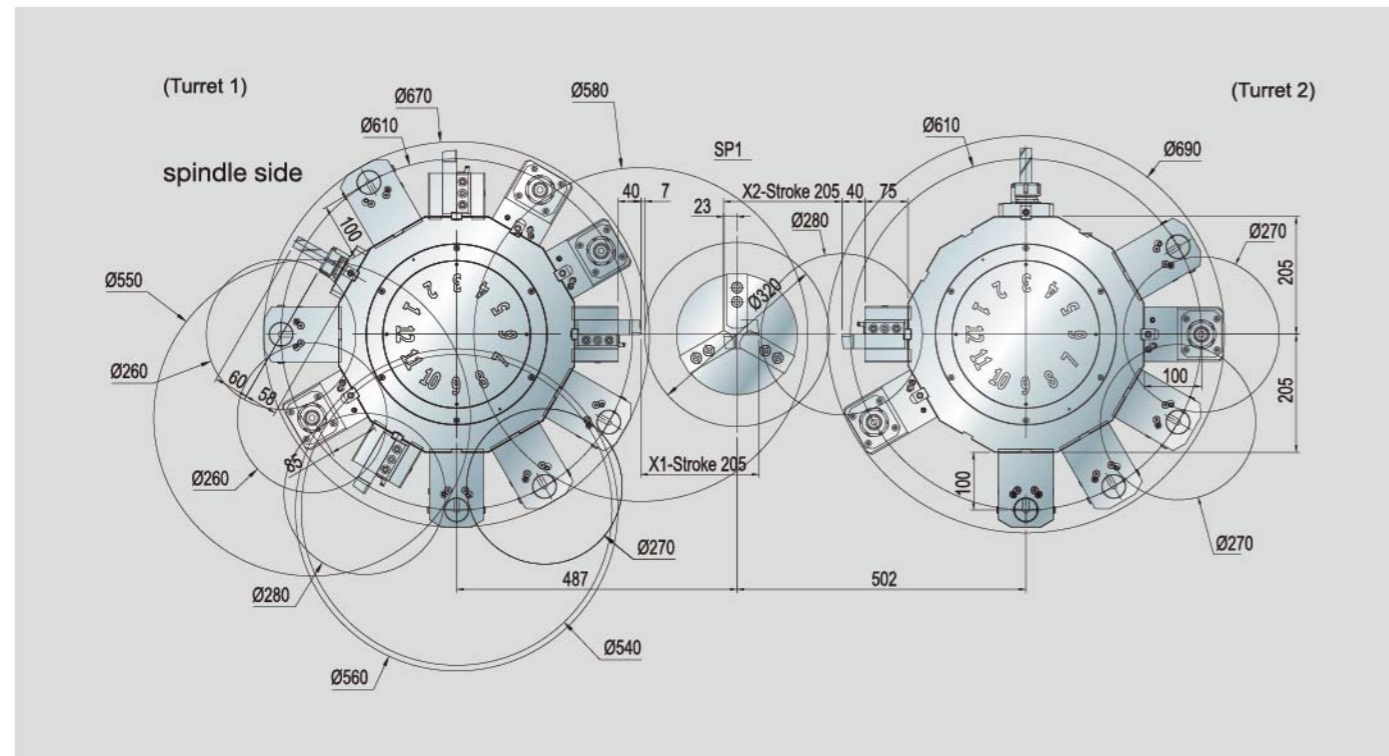

(Turret 3) ID tool holder with center height 100 mm/(Turret 2) ID tool holder with center height 100 mm

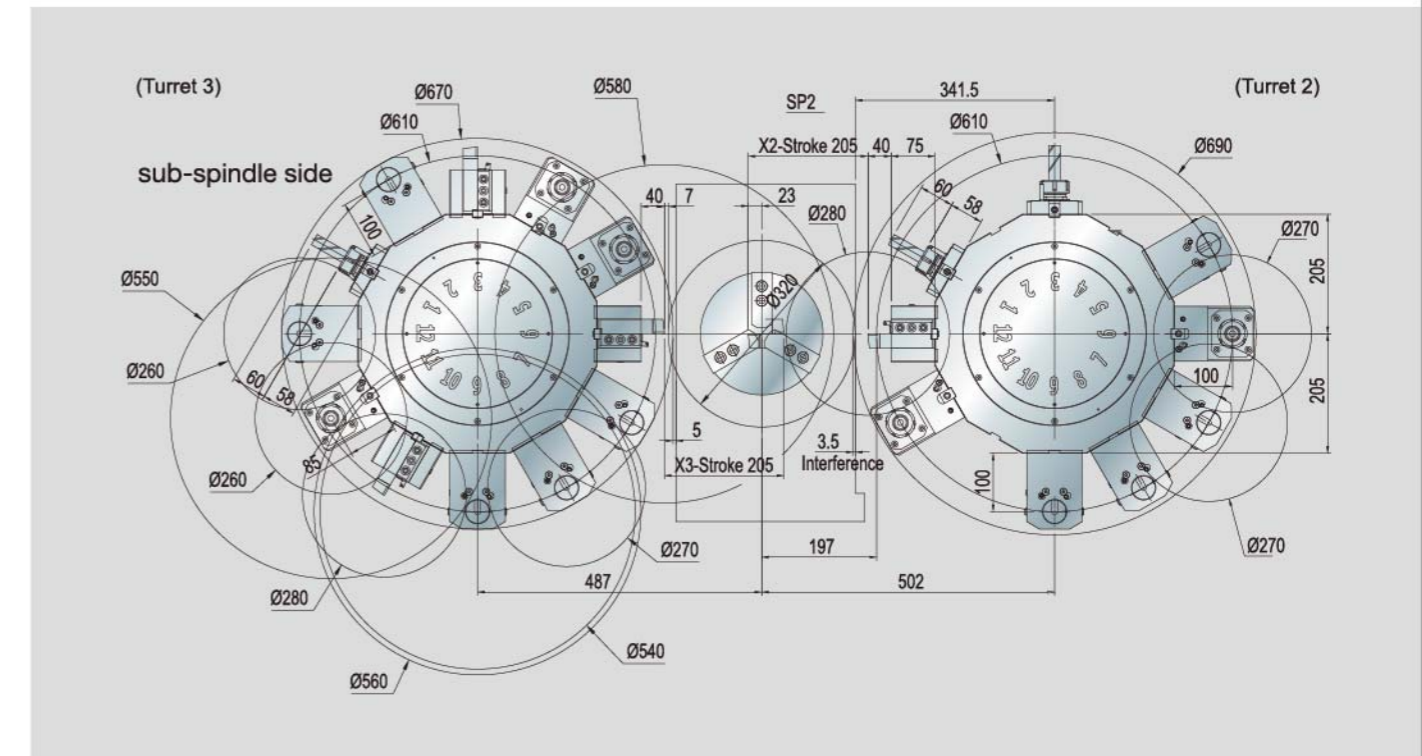

Working area TMT2000-T3Y2

Turret 1

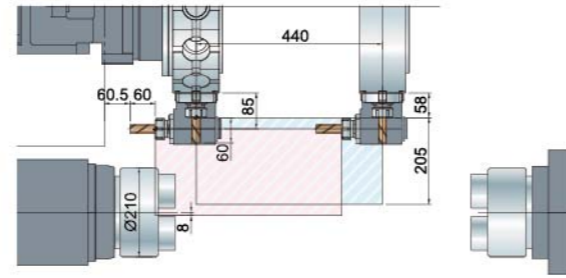
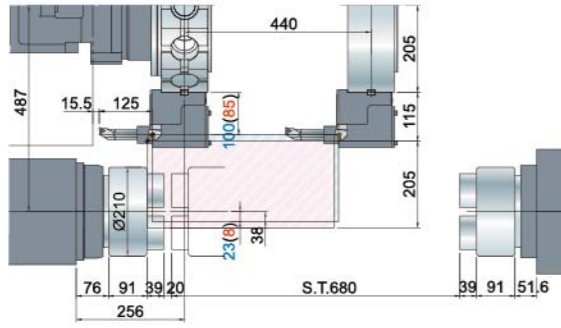

Turret 3

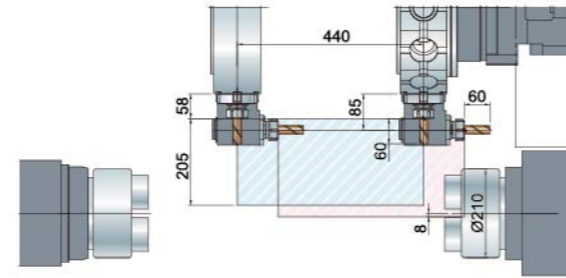
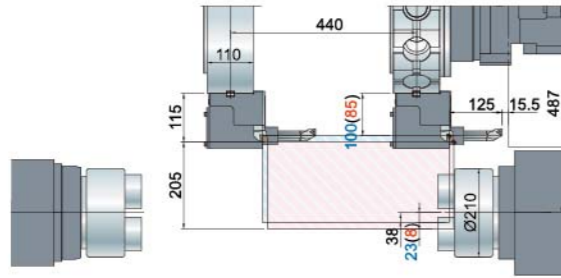

Turret 2

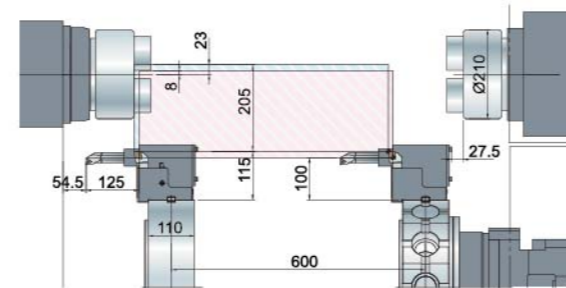
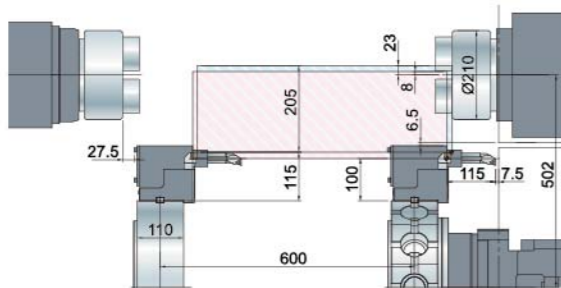

Turret 2

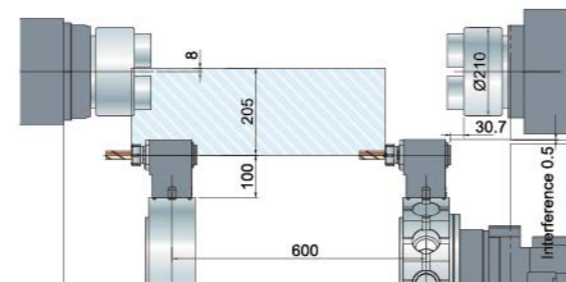
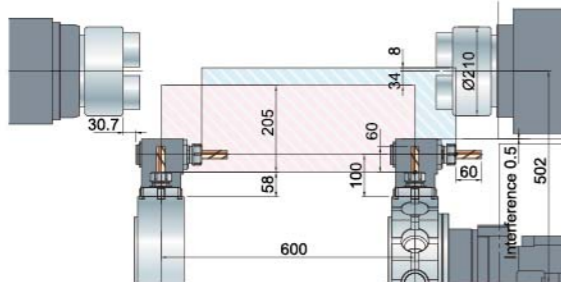

Unit : mm

TMT2000-T2Y1

Turret 1

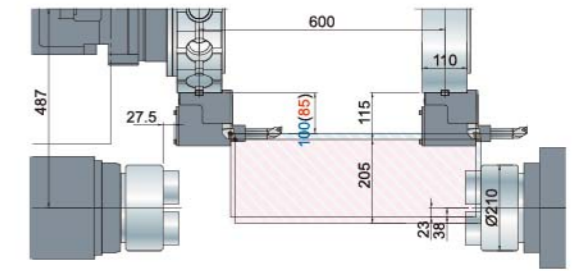
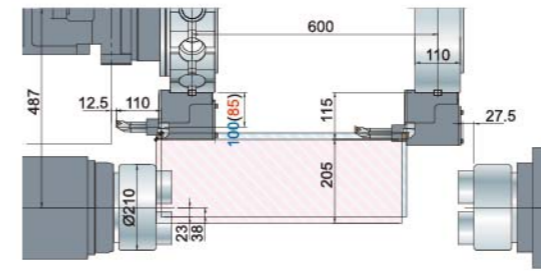

Turret 1

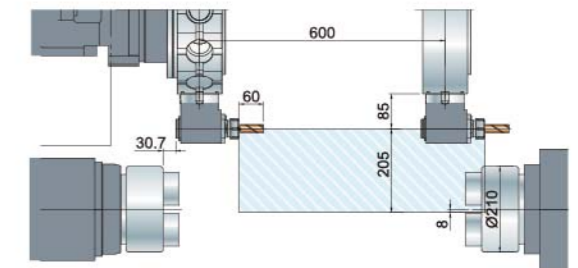
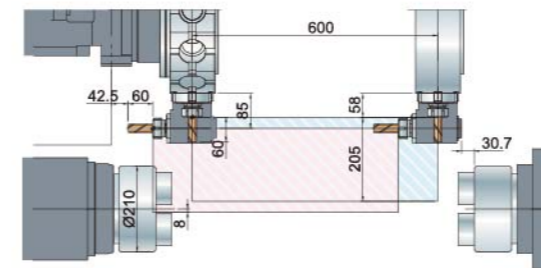

Turret 2

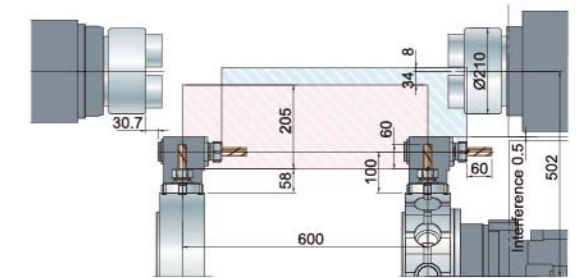
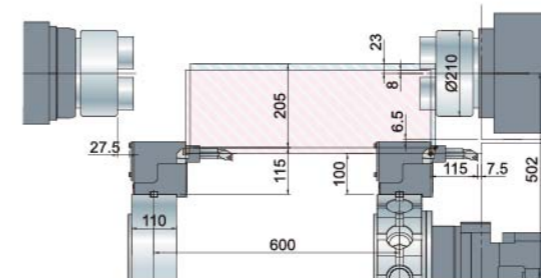

Turret 2

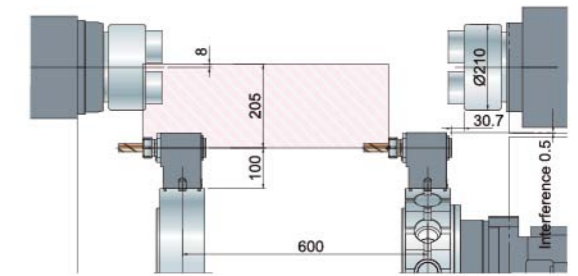
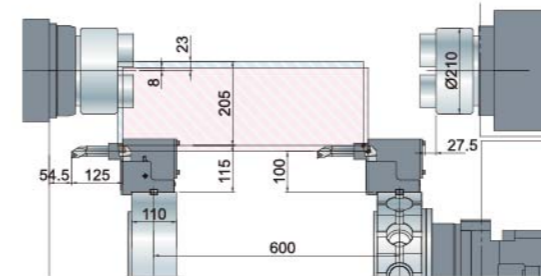

Unit : mm

Standard/optional accessories

Specifications

Machine dimension

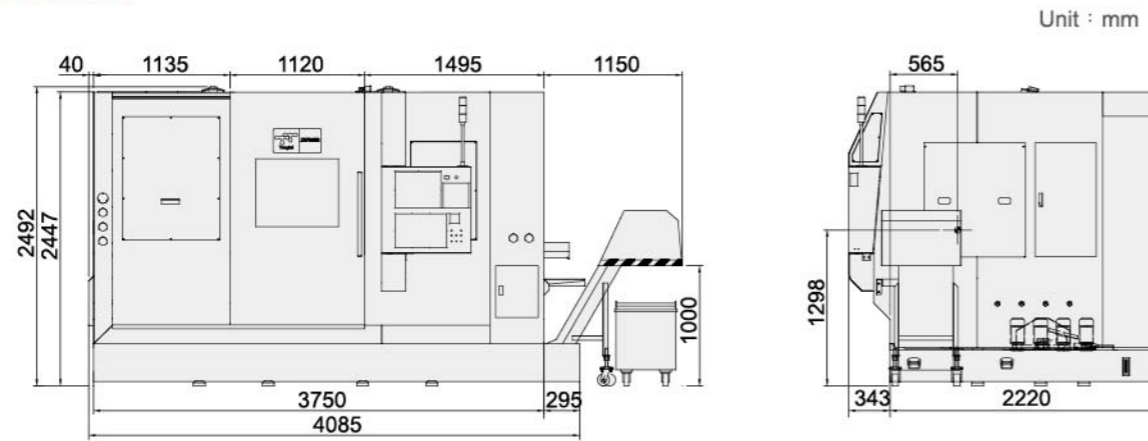

Accessories

		Standard	Optional
Chuck	Three jaws chuck	●	
	Collet chuck		○
Tool spec.	BMT-65	●	
	VDI-40		○
Chip conveyor	Hinge type	●	
	Scraper type		○
	Magnetic scraper type		○
	Drum type		○
Linear scale	5 μm Resolution		○
	3 μm Resolution		○
Coolant & air blow	Coolant through spindle/sub-spindle		○
	Air blow through spindle/sub-spindle		○
	Coolant on spindle/sub-spindle side		○
	Air blow on spindle/sub-spindle side		○
Automation equipment	Bar feeder		○
	Part catcher		○
	Part conveyor		○
	Sub-spindle part pusher		○
	Automatic door		○
Other accessories	Oil skimmer		○
	Oil mist collector		○
	Air conditioner for electrical cabinet		○
	Manual tool presetter		○
	3D Interference protection software		○
	Air gun		○
	Coolant gun		○

Item	Specification	Unit	TMT2000-T2Y1	TMT2000-T3Y2
Turning capacity	Max. swing diameter	mm	Ø720	Ø720
	Max. swing diameter over saddle	mm	Ø310	Ø310
	Max. turning diameter	mm	Ø320	Ø320
	Max. turning length	mm	600	600
Spindle	Spindle nose		A2-6	A2-6
	Spindle speed	rpm	4,500 (Opt. 6,000)	4,500 (Opt. 6,000)
	Chuck size	inch	8	8
	Through-spindle hole diameter	mm	Ø76 (Opt. Ø62)	Ø76 (Opt. Ø62)
	Bar capacity	mm	Ø65 (Opt. Ø51)	Ø65 (Opt. Ø51)
	Spindle bearing diameter	mm	Ø100	Ø100
	Spindle center to floor	mm	1,300	1,300
	Min. CS axis indexing increment	deg	0.001	0.001
	Sub-spindle	Spindle nose		A2-6
Spindle speed		rpm	6,000	6,000
Chuck size		inch	8	8
Through-spindle hole diameter		mm	Ø62	Ø62
Bar capacity		mm	Ø51	Ø51
Spindle bearing diameter		mm	Ø100	Ø100
Power turret	Tool shank		BMT-65	BMT-65
			(Opt. VDI-40)	(Opt. VDI-40)
	Tool capacity	pc	12×2	12×3
	O.D. tool	mm	25×25	25×25
	I.D. tool	mm	Ø40	Ø40
	Max. speed	rpm	6,000	6,000
	Spindle motor	kW	5.5/3.7	5.5/3.7
	Max. tool diameter	mm	Dia. 20/M16	Dia. 20/M16
	Index time	sec	0.3	0.3
	Driving system		Servo	Servo
Feed	X1/X2/X3 axis stroke	mm	205/205/-	205/205/205
	Y1/Y2/Y3 axis stroke	mm	±51/-/-	±51/-/±51
	Z1/Z2/Z3/B axis stroke	mm	600/600/-/680	440/600/440/680
	X/Y/Z/B axis rapid traverse	m/min	30/15/36/30	30/15/36/30
	Cutting feedrate	mm/rev	0.001-500	0.001-500
Hydraulic unit	Hydraulic tank capacity	L	40	40
	Hydraulic motor	kW	3HP×4P	3HP×4P
Coolant unit	Coolant tank capacity	L	700	700
	Coolant motor	kW	0.55×3	0.55×4
Motor	Spindle motor (50% ED)	kW	15/11	15/11
	Sub-spindle motor (50% ED)	kW	18.5/11	18.5/11
	X/Z/B axis servo motor	kW	4/3/4/3	4/3/4/3
Controller	FANUC 31i			
Machine size	L×W×H	mm	4100×2600×2450	4100×2600×2450
	Weight	kg	8200	9000